

FISCHBEIN CO.

THE LEADER IN BAG CLOSING TECHNOLOGY

OPERATOR'S MANUAL

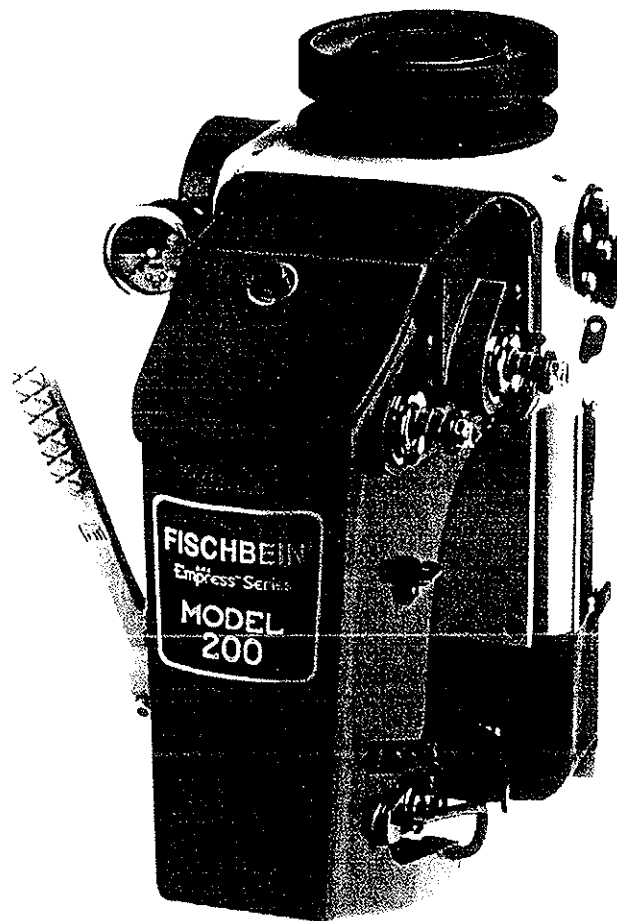

EMPRESS™ SERIES

Model 200 and 201 Sewing Heads



Rev. G 7/2002
Part No. 35086

TABLE OF CONTENTS

	Page
Corporate Statement	2
1. Introduction	3
1.1 System Description	3
1.2 Warnings	4
1.3 Characteristics	5
2. Installation	7
2.1 Unpacking Procedures	7
2.2 Drive motor recommendations	7
2.3 Mounting the Sewing Head	8
2.4 Lubrication	10
2.5 Maintenance	11
2.6 Start up recommendations	12
2.7 Consumables	12
3. Machine Adjustments	14
3.1 Threading the sewing head	14
3.1.1. Needle and Looper Thread	14
3.1.2. Filler Cord (Optional)	15
3.2 Thread tension adjustment	16
3.3 Stitch length adjustment	18
3.4 Cork seal replacement	19
3.5 Needle replacement	20
3.6 Feed dog replacement	20
3.7 Throat plate replacement	21
3.8 Presser foot pressure adjustment	21
3.9 Fine tuning of the sewing machine	22
3.10 Tape/Thread Clipper Adjust (model 201 only)	28
3.11 Installing new blades (model 201 only)	29
3.12 Mounting & Adjusting the Rotary Air Knife (model 200 only)	30
3.13 Using the Gauge	33
3.14 Sewing speed adjustment	34
4. Speed tables	39
4.1 English System	39
4.2 Metric System	40
5. Opening a sewn bag	41
6. Troubleshooting	42
7. Spare Parts List	46
8. Drawings and Parts Lists	47
9. Machine Set Up Parts Lists	77
10. Safely Disposing of a Sewing Head	78

READ

**READ THIS MANUAL BEFORE INSTALLING, OPERATING OR
PERFORMING MAINTENANCE ON THE MODEL 200 OR 201
EMPRESS™ SEWING HEAD.**

CORPORATE STATEMENT

The Fischbein Company is a premier packaging company that specializes in bag closing systems. The original one-man business, founded and established by Dave Fischbein in Minneapolis, Minnesota in 1910, has now grown to an international firm recognized as the global leader in bag closing technology which manufactures a variety of state-of-the-art bag closing and handling machines for diverse packaging applications. Fischbein's first portable sewing machine for bag closing was developed over 50 years ago and is still widely used throughout the world for a variety of bag closing applications. Through our bag sewing, closing and sealing technologies, Fischbein offers automated solutions for nearly every powder and bulk material packaging requirement.

The product line has greatly expanded from those early days, and the company continues to lead the industry in helping customers increase productivity through improved product performance with efficient, up-to-date automated packaging solutions.

A worldwide network of distributors assists our customers in meeting their technological requirements and their business objectives. Orders, questions and comments can be addressed to Fischbein through the worldwide web at www.fischbein.com or by writing or calling our North American or European offices:

North American Office

Fischbein Company
151 Walker Road
Statesville, NC 28625
Phone: (704) 871-1159
FAX: (704) 872-3303

Main European Office

Fischbein SA
Paepsem Business Park
Boulevard Paepsem 18B
1070 Brussels, Belgium
Phone: 32-2-521-01-94
FAX: 32-2-520-33-90

1. INTRODUCTION

The contents of this manual are considered to be proprietary and confidential to FISCHBEIN AND SHOULD NOT BE REPRODUCED WITHOUT PRIOR WRITTEN PERMISSION FROM FISCHBEIN.

Nothing contained in this document is intended to extend any promise, warranty or representation, expressed or implied, regarding the FISCHBEIN products described herein. Any such warranties or other terms and conditions of products shall be in accordance with the standard terms and conditions of sale for such products, which are available upon request.

FISCHBEIN reserves the right to make changes and improvements to products without notice and without incurring any obligation to make such changes or add such improvements to products sold previously.

The use of repair parts other than those included within the FISCHBEIN approved parts list may create hazardous conditions over which FISCHBEIN has no control. Therefore, FISCHBEIN cannot be held responsible for equipment in which non-approved repair parts are installed.

1.1 SYSTEM DESCRIPTION

The Fischbein 200 and 201 sewing heads are heavy duty, commercial sewing machines. These heads sew bags of different materials, such as plastic, woven polypropylene, multi-wall paper bags, composite bags, jute bags and so forth.

For proper operation, these heads are normally mounted on Fischbein double pedestal stands and conveyor systems. These enable adjustment of the system for bag height and bag speed through the system. A variety of infeeds and other special attachments (such as a rotary knife and a needle cooler) are available to enhance and support the operation of the head.

Model 200

This model is intended for standard sewing, two-thread applications. Standard head with rotary knife at 115 VAC.

Model 200LV

Same as 200 standard head with rotary knife at 24VAC.

Model 200DC

Same as 200 standard head with rotary knife at 24VDC.

Model 201

This model is intended for two or single-thread applications, using tape or pull tape attachments.

1.2 WARNINGS

- The model 200 and 201 sewing heads are driven by strong motors, contain moving parts and have pinch points and sharp edges. Therefore, a certain amount of technical knowledge and familiarity with this type of equipment are required to operate and maintain the system. Proper eye, hand and foot protection must be worn while working with the 200 and 201 sewing heads.
- The sewing head is not a stand-alone machine; therefore, care must be taken to provide the correct drive system and proper protection from the drive components. You should follow the recommendations in the manual about the drive system.
- Read the manual carefully before making any changes to the sewing head.
- Replacement of the Connecting Needle Drive Rod (pages 52-55; Item 20: part#31020) and the bushings for the main shaft (page 64-65) must be performed by an authorised Fischbein representative, equipped with the special tools necessary.
- Always use **genuine** Fischbein spare parts (including Fischbein Lubricating Oil and Fischbein Oil Filters). Our parts are specifically designed for Fischbein equipment to provide optimum performance and safety. Use of non-Fischbein parts can also void product warranty.
- Turn off and lock out air and power sources when performing maintenance.
- Let the machine do the work. Do not pull the bag or the materials through it.
- Consult Fischbein concerning your specific application and sewing need.
- The sewing head is not suitable to operate in an area where explosive materials are present (explosive gas, vapors, powders or liquids).
- When used in a dusty environment, NEMA 12 (IP54) electrical equipment must be used.
- Frequently clean the machine to prevent accumulation of dust. Do this to prevent accumulation of material that may cause a fire or malfunction.
- When cleaning the optical controls that may come with the sewing head, consult the accompanying manuals from the optical manufacturer. These additional manuals can be found in the electrical control box with the electrical schematics.
- Any sources of leaks of the machine's lubricating oil must be repaired immediately to prevent possible contamination of the product being packed and safety hazards around the system.
- When cleaning the sewing head, use only recommended Fischbein cleaning solvent 5-101.
- Do not use aggressive cleaning products as they may damage the rubber seals.
- When in doubt about operation, troubleshooting and maintenance of the sewing head, consult your dealer or local Fischbein representative.
- Other specific warnings appear throughout this manual.

**FISCHBEIN® MODELS 200 & 201 EMPRESS™ SERIES SEWING HEAD
OPERATOR'S MANUAL**

1.3 CHARACTERISTICS

Maximum speed:	2600 rpm
Stitch length:	2 – 4 stitches per inch
Net Weight:	Model 200: 63 lbs. (28,6 kg) Model 201: 65 lbs. (29,5 kg) (with Tape Clipper)
Shipping Weight:	Model 200: 66 lbs. (30 kg) Model 201: 68 lbs. (30,9 kg) (with Tape Clipper)
Oil:	1 qt (0.95 litres) Mobil SHC 626 Synthetic Oil

Maximum speed with a stitch length of 4 stitches per inch is 2600 RPM.
(Refer to Speed Tables, pages 39 and 40)

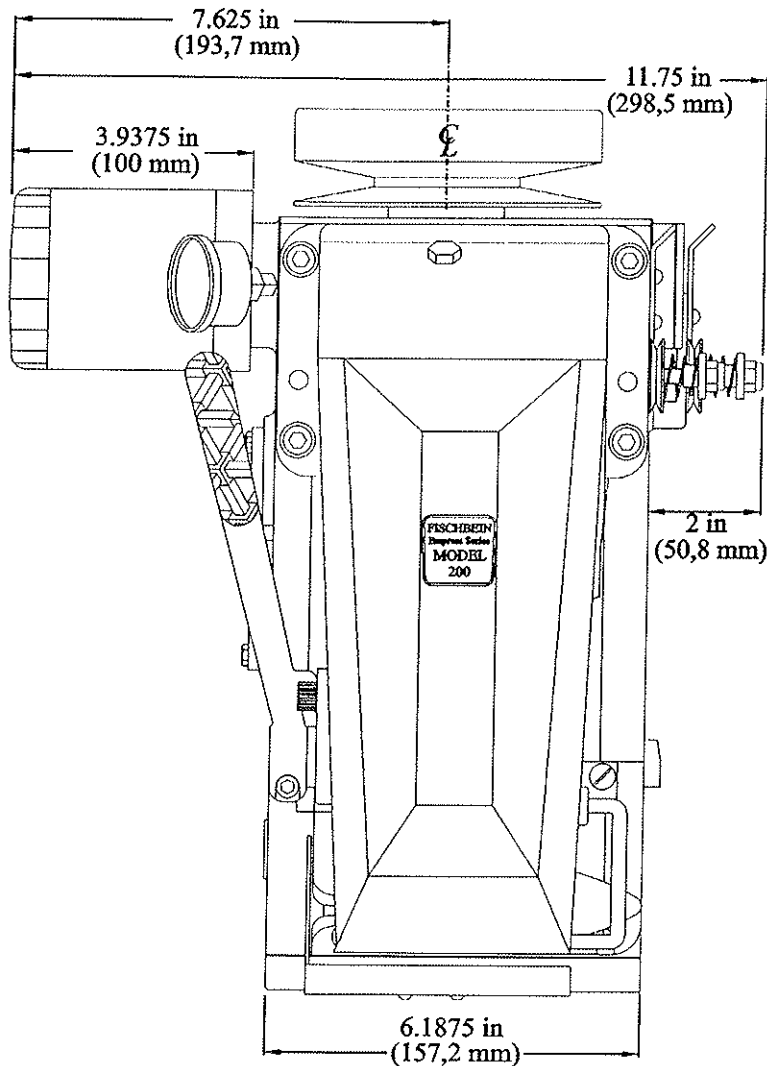

FRONT VIEW

**FISCHBEIN® MODELS 200 & 201 EMPRESS™ SERIES SEWING HEAD
OPERATOR'S MANUAL**

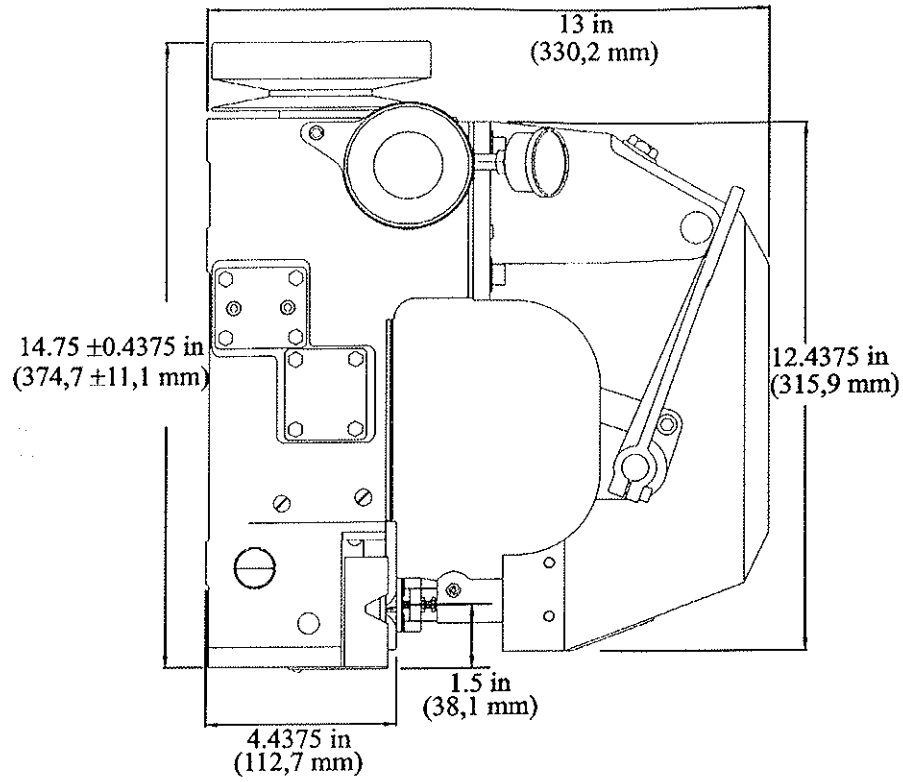

LEFT VIEW

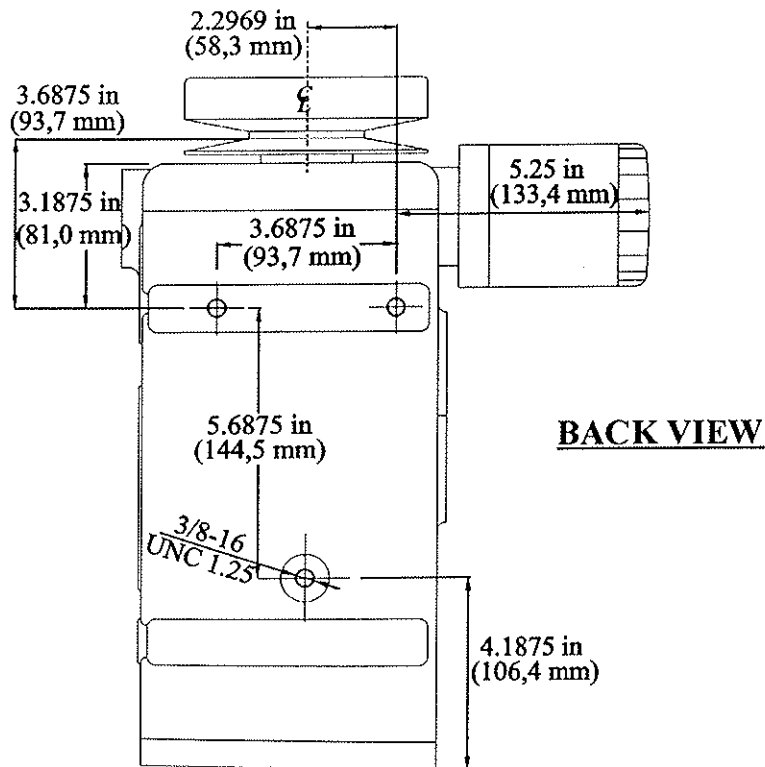

BACK VIEW

2. INSTALLATION

2.1 UNPACKING PROCEDURES

Every Fischbein sewing head is packaged to protect the unit during normal shipping, storage and handling. Each sewing head is packed in a corrugated box with cardboard padding surrounding it. It is then taped shut. Before the unit is unpacked, inspect the box for any signs of damage incurred during shipping. After the unit is unpacked, inspect the sewing head itself for damage. Report any damages in writing to the shipper and to your authorized Fischbein representative. Be sure to locate your sewing head's serial number and model number and record these numbers for future reference. Reading from left to right, the first six numbers that are stamped on the housing represent the serial number. The next three numbers represent the model number. The model number and serial number are also printed on the plate attached to the side of the housing.

The sewing head is very heavy and can be awkward to handle alone. For safety of the installers and the sewing head, a dolly platform should be used to transport the sewing head.

2.2 DRIVE MOTOR RECOMMENDATIONS

A 1.5 hp or 1.12 kW motor is recommended.

**WARNING: MAXIMUM RPM FOR THE SEWING HEAD IS
2600 RPM AND MUST NOT BE EXCEEDED.**

2.3 MOUNTING THE SEWING HEAD

Due to the size and weight of the sewing head, a dolly cart should be used to transport it. It is best to have a couple of installers handling the sewing head. Be sure to hold it by the main housing.

The sewing head is attached to the overarm assembly by a mounting plate, which mounts to the back of the housing with three hex head bolts (**Illustration 2**). It is extremely important that these bolts be securely tightened to the sewing head, because of the vibration common to high performance systems.

Refer to **Illustrations 1 and 2**. The mounting plate attaches to the overarm assembly with two hinges. The hinges allow for easy access to various areas of the sewing head as well as the cooling fan (optional). When the sewing head is rotated into the closed position, the outer swinging edge of the mounting plate will come to rest on two jack bolts. The jack bolts are used to provide the needed support during use and enable the latch pin to firmly hold the plate. The mounting plate is locked into the closed position with a latch pin, which is pushed in and rotated to secure the mounting plate. (**Illustration 3**) The locking rod passes through a hole in the sewing frame and then through one in the mounting plate, when in the closed position.

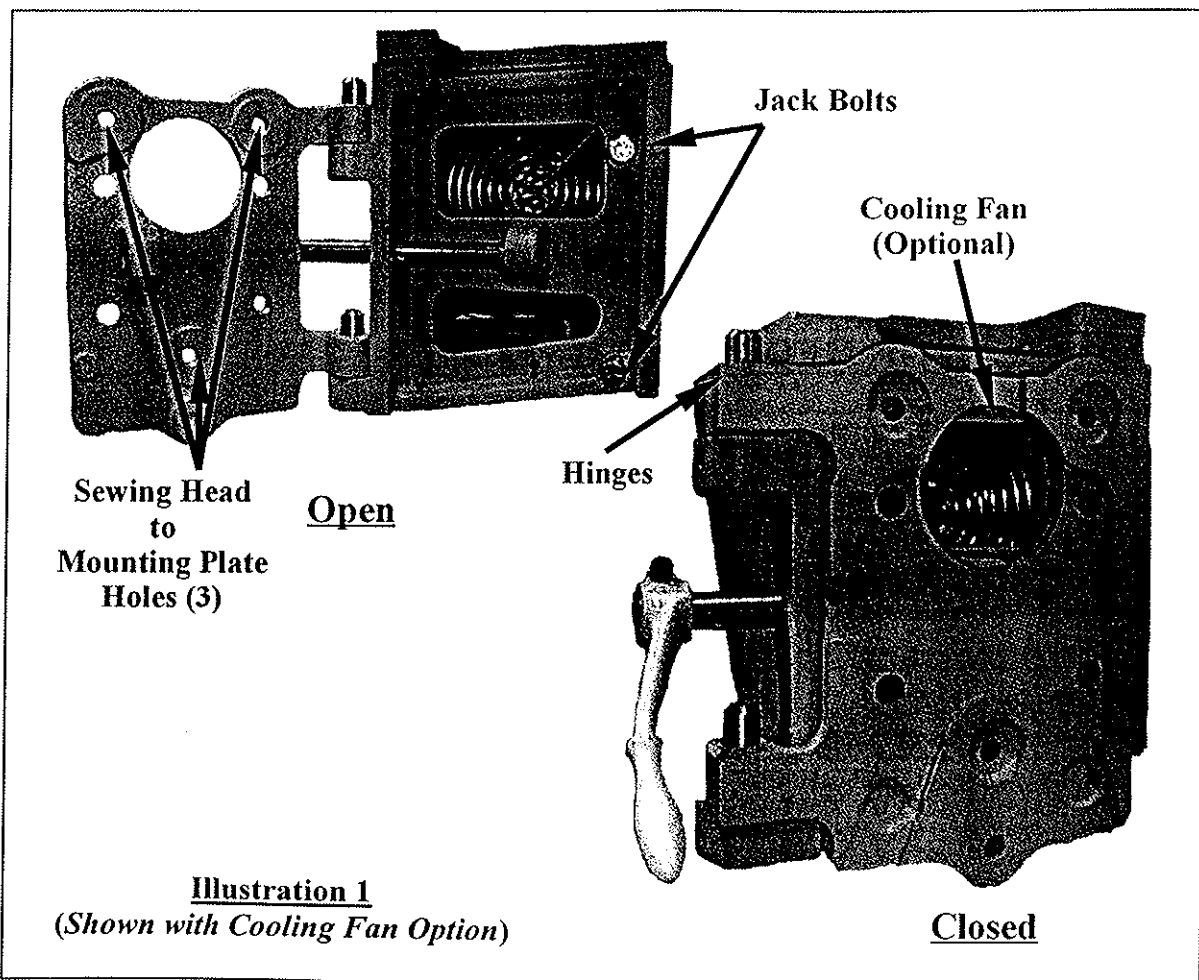

**FISCHBEIN® MODELS 200 & 201 EMPRESS™ SERIES SEWING HEAD
OPERATOR'S MANUAL**

If the jack bolts are not properly adjusted, the sewing head can vibrate possibly causing damage or other parts to come loose. The jack bolts must be raised or lowered so that they come into firm contact with the mounting plate. Both bolts come with a lock nut to keep them in position.

The jack bolts are pre-set at the factory for the mounting plate that accompanies the sewing system. The jack bolts will only have to be adjusted if they become loose or if replacing the plate. To adjust the jacks, loosen the lock nuts and turn the jack bolts clockwise for about five turns. Rotate the plate into the closed position until it comes into contact with the jacks and then use the latch pin to secure the plate. The pin will probably rotate with ease and not actually tighten when turned. Gradually keep trying the latch pin, while turning the lower jack in increments, counterclockwise. The ideal setting for the lower jack is when the latch pin tightens firmly before it has rotated the full 90°. (Illustration 3) Use the lower lock nut to hold it in position.

Gradually turn the top jack counterclockwise until it comes into contact with the plate, when it is in the closed position, but not locked with the pin. Unscrew the top jack one additional rotation. Lock the top jack into position using the lock nut. When the plate is in the closed position and secured into place, the latch pin will tighten completely before rotating the entire 90° and press firmly on the jack bolts.

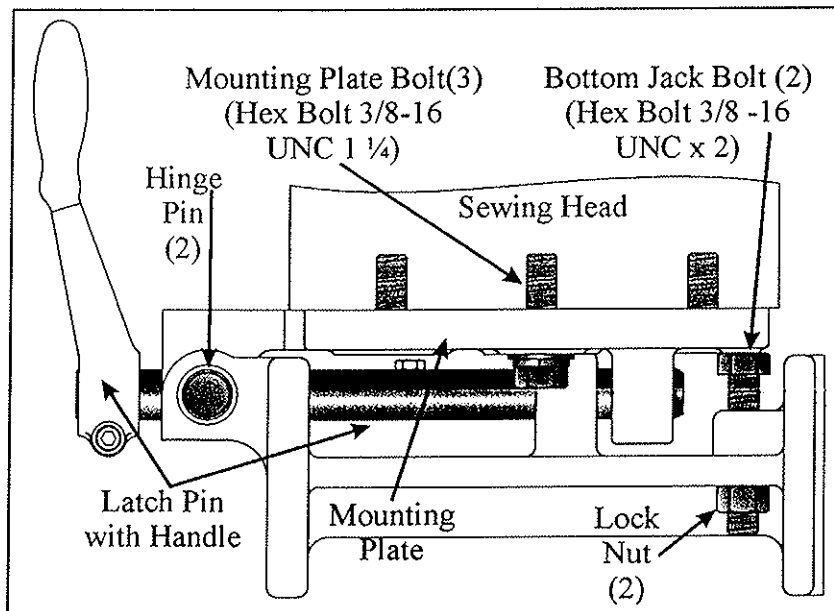

Illustration 2 (Bottom View; sewing head in closed position)

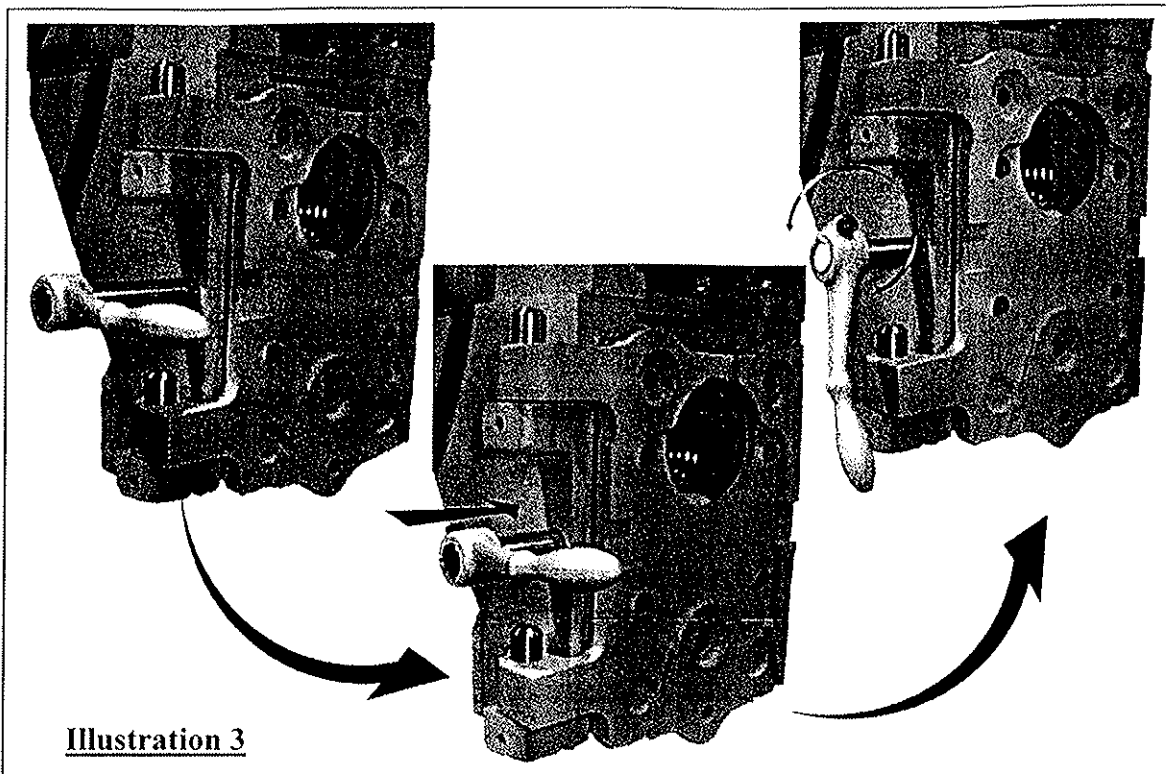

Illustration 3

2.4 LUBRICATION (WARNING)

Refer to **Illustration 5**. The sewing head is delivered with a screw in the breather plug. Remove this screw before starting up the head. Failure to remove this will result in build up of internal pressure and consequent damage to seals and other components with possible injuries to the operator.

The sewing head is filled at the factory with oil (1 qts. or 0.95 litres). SHC 626 Synthetic Oil

Pre-start up checks:

- Check oil level (indicated on the oil window on the left side of the machine). (**Illustration 4**)
- Check for indications of oil leaks. If any are found, perform the appropriate repair.
- After a few seconds, the oil pressure gauge should indicate a pressure between 15 PSI (1 bar) and 40 PSI (2,8 bar).

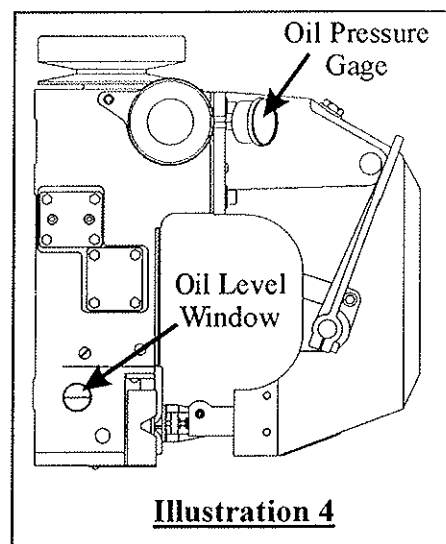

Illustration 4

WARNING: Do not run the machine with oil pressure below 15 PSI (1 bar) or above 40 PSI (2,8 bar).

FISCHBEIN® MODELS 200 & 201 EMPRESS™ SERIES SEWING HEAD OPERATOR'S MANUAL

- Replace the oil filter every **1000 working hours** (see **Section 2.5**).
- Replace the oil every **1000 working hours** (see **Section 2.5**).
- Approximately 1 qt or 0.95 litres will adequately fill the machine. SHC 626 Synthetic oil (ref. 31080) must be used.
- Check the oil level when the machine is operating and the pressure is in the specified range 15-40 PSI (1-2.8 bar). **Note:** The pressure must be checked after the machine has fully warmed up (1.5 – 2 hours of operation).
- In the event the oil level falls below the marker line, add oil until level is met.

2.5 MAINTENANCE:

NOTE: A certain amount of technical knowledge is required to perform any maintenance on Fischbein sewing heads.

DAILY

1. Keep the machine free of dust.
2. Clean with compressed air, using an OSHA approved air nozzle or with a vacuum cleaner.
3. Check all seals for indications of oil leaks before start up.
4. Lubricate knife blades and presser foot hinges manually with standard lubricating oil. Wipe all excess oil from parts.
5. Keep optical sensors clean according to their individual manual instructions.
6. Thoroughly, check for loose fasteners and tighten them back into position. If the loose fastener holds a specific component in place that has a critical setting, refer to the appropriate section of this manual to establish the correct setting.

PERIODIC - OIL CHANGE

Oil changes are part of periodic maintenance performed after **1000 hours** of operation. (Illustration 5)

1. Lock out compressed air and electrical power so the machine cannot run.
2. Remove breather plug (A).
3. Unscrew the drain plug (B) in the bottom cover (C).
4. Drain the used oil into a tray.
5. The drain plug (B) is magnetic. Remove metal particles and dirt sticking to it.
6. Wrap new Teflon® tape around the drain plug (B).
7. Screw the plug (B) into the bottom cover (C).

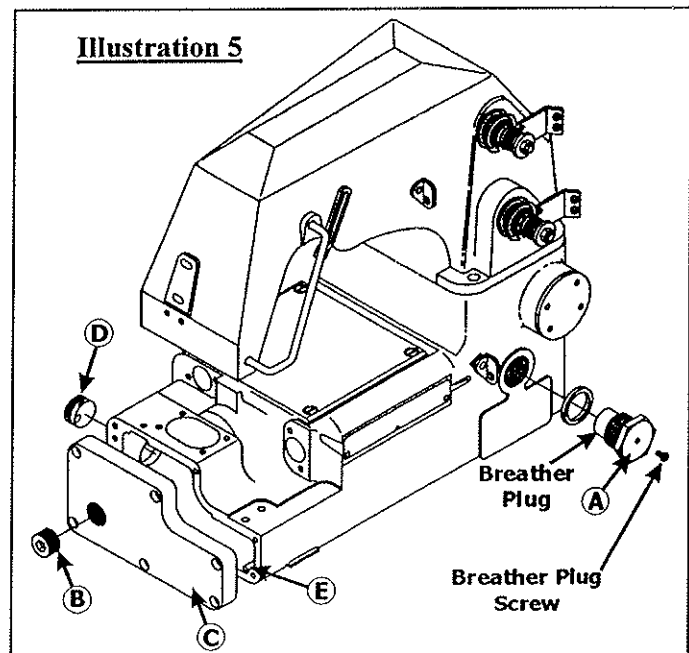

Teflon is the registered trademark of DuPont U.S.A.

FISCHBEIN® MODELS 200 & 201 EMPRESS™ SERIES SEWING HEAD
OPERATOR'S MANUAL

8. Fill the machine with one quart (0,95 litres) of oil through the breather plug hole (A). A funnel and flexible tube are provided with the tool kit.
9. Re-install the breather plug (A).
10. Follow the recommendations for daily operation in **Section 2.6**.

PERIODIC - OIL FILTER REPLACEMENT

Oil filters are part of periodic maintenance performed after **1000 hours** of operation. (Illustration 5)

1. Lock out compressed air and electrical power so the machine cannot run.
2. Fill the replaced filter with oil.
3. Use a *genuine* Fischbein oil filter, ref. 15054.
4. Coat the seal on the new oil filter with a thin film of oil.
5. Remove the old oil filter.
6. Install the new filter (hand tightening is sufficient).
7. Run the sewing head in short, 2 to 3 second cycles until the filter is filled and the pressure falls in the normal 15 to 40 PSI (1-2,8 bar) range.

2.6 START UP RECOMMENDATIONS

2.6.1 *DAILY USE:* Initially, start the machine in short, 2 to 3 seconds cycles until the correct oil pressure is reached.

2.6.2 *Running after prolonged shut down (two months and over):* Replace the oil and filter and follow procedure 2.5.

2.7 CONSUMABLES

The Fischbein Company recommends using Fischbein cleaning solvent (ref. 5-101), SHC 626 Synthetic oil (ref. 31080), Fischbein oil filter (ref. 15054) and Fischbein sewing thread. Sewing heads Model 201 use crepe sewing tape, available in a variety of basic colors and widths. Seals, gaskets, knife blades, belts and any other part subject to normal wear should be replaced with genuine Fischbein spare parts. If in doubt, contact your Fischbein representative.

**FISCHBEIN® MODELS 200 & 201 EMPRESS™ SERIES SEWING HEAD
OPERATOR'S MANUAL**

**WARNING: ALWAYS LOCK OUT THE
ELECTRICAL AND PNEUMATIC SYSTEMS
BEFORE WORKING ON THE SEWING HEAD!**

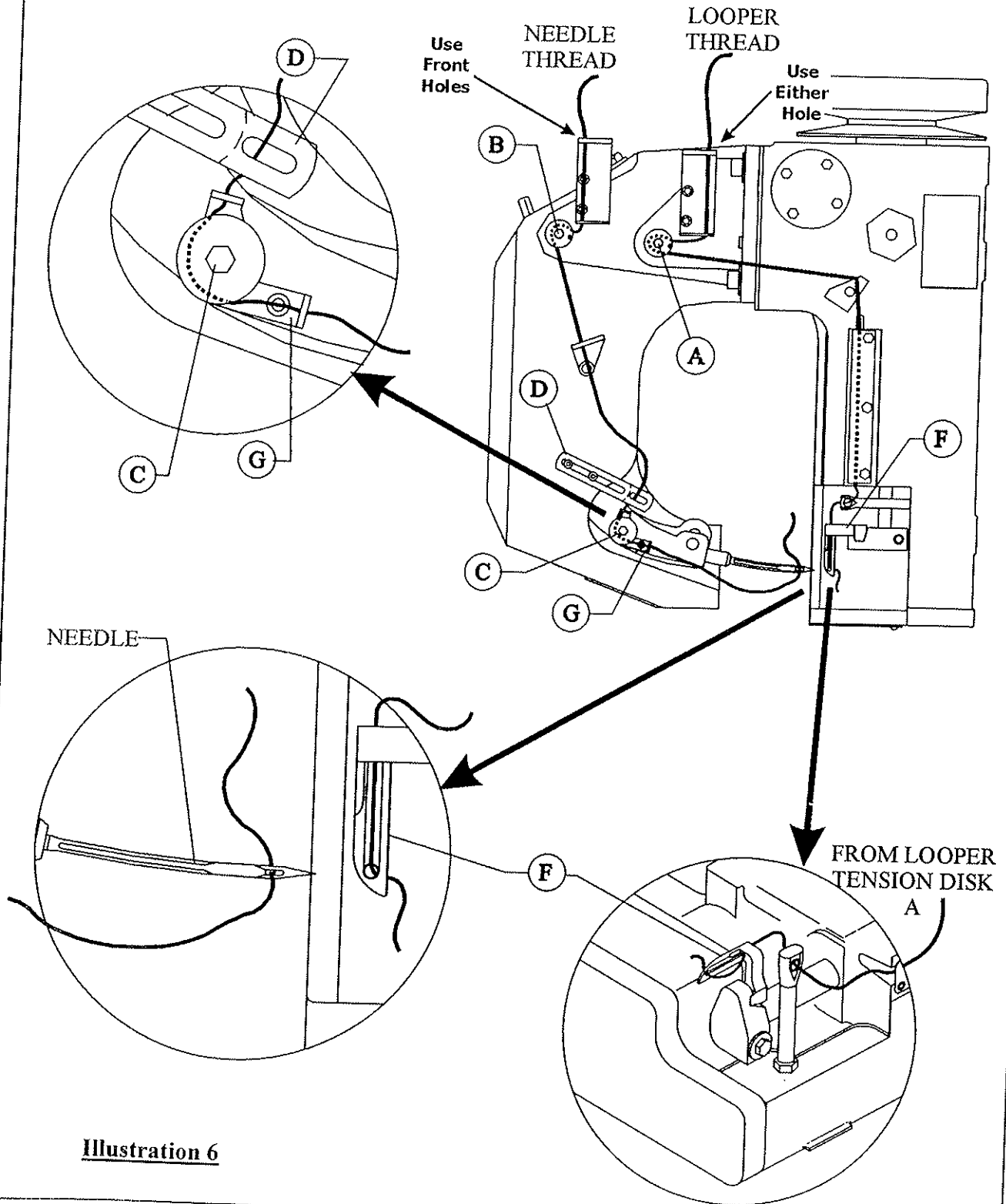

Illustration 6

3. MACHINE ADJUSTMENTS

3.1 THREADING THE SEWING HEAD

3.1.1 LOOPER AND NEEDLE THREAD

1. Lock out compressed air and electrical power so the machine cannot run.
2. Refer to **Illustration 6, page 13**. Thread the needle as shown. A pair of needle nose pliers may help in threading small areas.
3. The thread at the needle is laced through from machine's infeed side towards the needle. Let the thread stick out 4" (102mm) on the other side of the needle.
4. Ensure that the thread runs properly through the thread-tensioning discs **B & C**.
5. Thread the looper (**F**) as shown.
6. The thread at the looper (**F**) must first go through the top hole and then through the bottom hole. About 4" (102mm) should be left sticking out of the looper. (**Illustration 6**).
7. To complete a chain off, a piece of bag material should be placed between the presser foot and the throat plate before running the machine. Loosen the sewing head drive belt tension. Turn the pulley by hand in a clockwise direction so the sewn bag proceeds forward through at least three complete cycles. This will start the chaining process. Run the system to clear out the test bag material, before attempting to run a bag through the system. *If this procedure is not followed, it will not start a chain and the machine might break the needle.*
8. A Model 201 tape sewing head must have tape between the presser foot and feed dog to operate. Check the looper to ensure no thread has accumulated around it.

3.1.2 FILLER CORD (OPTIONAL)

1. Lock out electrical and pneumatic systems before attempting to thread the filler cord.
2. Follow **Illustrations 6, 7 and 8** to thread the filler cord with the looper and needle thread.
Note that the filler cord does NOT get threaded through the thread pull off.
3. Once the thread has been threaded through the Filler Cord Eyelet (**Illustration 7**), it will be threaded through the presser foot as shown in **Illustration 8**.
4. The bottom of the presser foot is designed with a channel, which runs from the filler cord hole to the back of the presser foot.
5. To complete a chain off, a piece of bag material should be placed between the presser foot and the throat plate before running the machine. Turn the pulley by hand in a clockwise direction so the sewn bag proceeds forward through at least three complete cycles. Run the system to clear out the test bag material, before attempting to run a bag through the system. *If this procedure is not followed, it will NOT start a chain and the machine might break the needle.*
6. The needle thread should actually be sewn through the filler cord. Be sure to leave about 4 inches (102 mm) of filler cord (chaining) out past the back of the presser foot before running the first bag through the system.
7. It is very important to keep the needle thread and the filler cord separated and not to let them accidentally twist together while threading or running the sewing system.

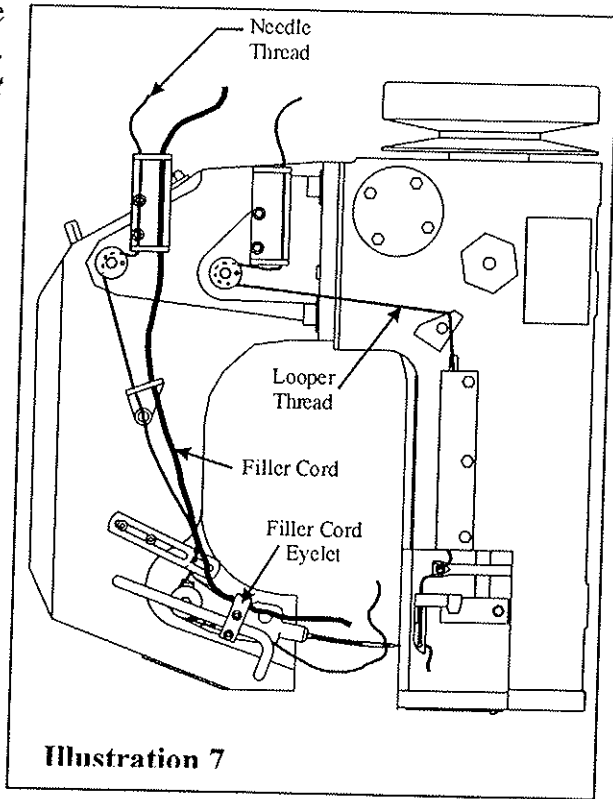

Illustration 7

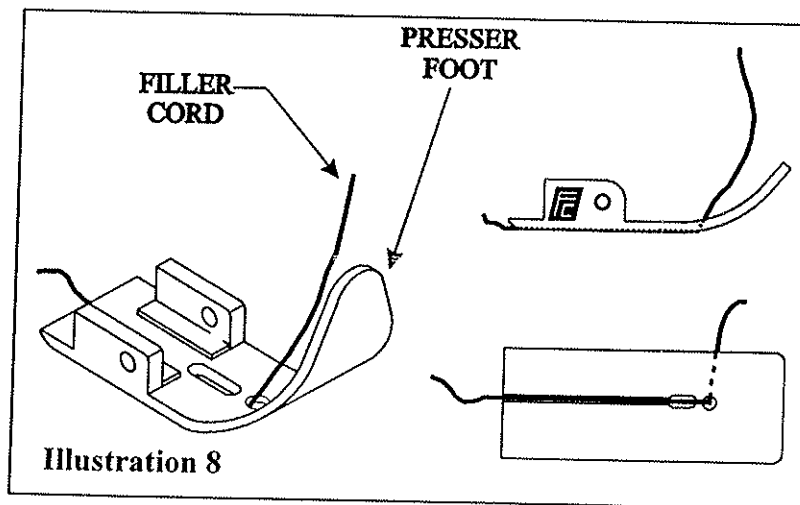
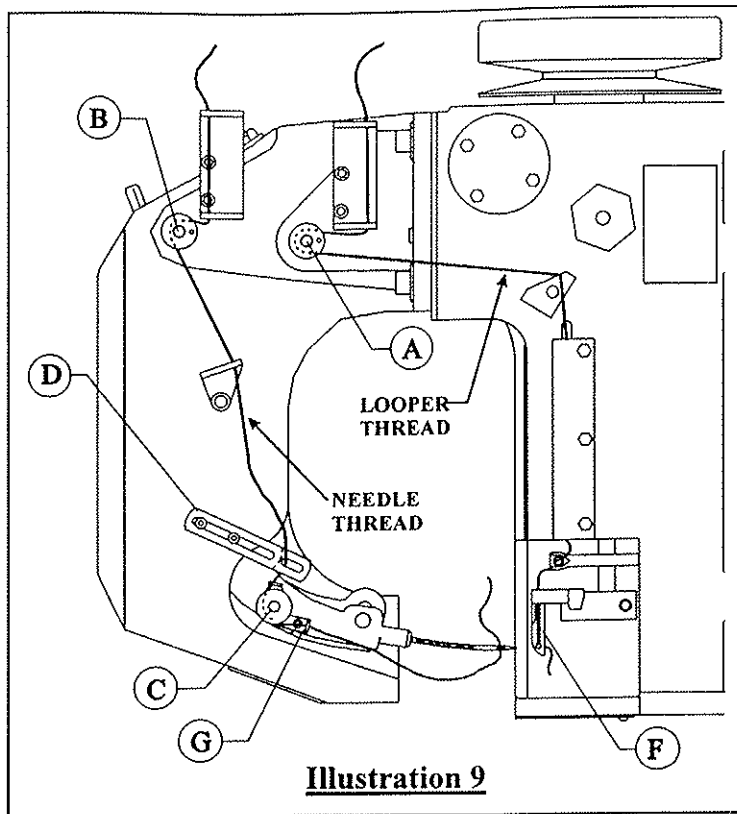

Illustration 8

3.2 THREAD TENSION ADJUSTMENT

1. Looper thread tension (A):

The tension on the looper thread must be light and even as the thread is pulled with a steady, even motion. If the tension is not even, or a large force is required to pull the thread, the source of the problem must be found and corrected before running the machine.



2. Needle thread tension (B):

Illustration 9. The needle thread tension is adjusted with the thread tensioner (B). The needle thread tension should put a noticeable drag on the thread. Tension also varies with stitch length and thickness of material to be sewn.

This adjustment can be combined with thread pull off positioning (D). On the needle arm, thread tensioner (C) prevents thread pulled by the thread pull off from sagging too close to the needle. Tension is very slight and the adjustment is fixed. Factory settings of tension are made for a 4-ply paper bag with a stitch length of 2.5 stitches per inch (10 mm per stitch) using Fischbein synthetic thread 12/5, unless otherwise specified when ordered, which is valid in most cases.

**FISCHBEIN® MODELS 200 & 201 EMPRESS™ SERIES SEWING HEAD
OPERATOR'S MANUAL**

3. Thread pull off adjustment

Illustration 10 shows the factory setting. This is suitable in many cases.

For thin materials, distance \mathcal{X} must be *shorter*.

For thick materials, distance \mathcal{X} must be *larger*.

If the stitch is too loose, try first to adjust with the needle thread tension before shortening the distance \mathcal{X} of the thread pull off.

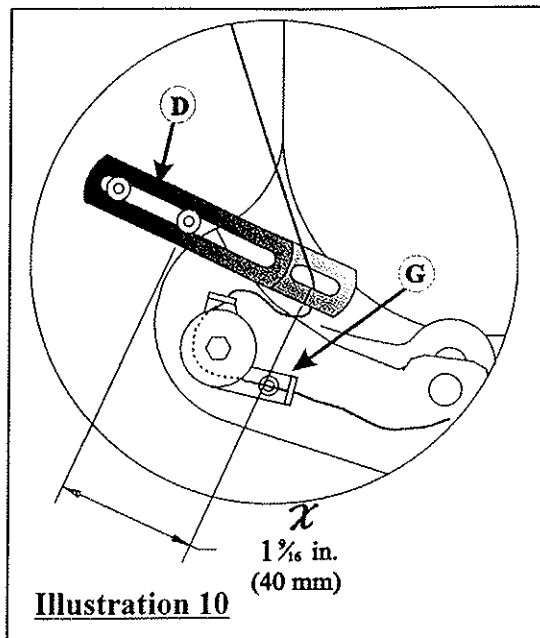

3.3 STITCH LENGTH ADJUSTMENT

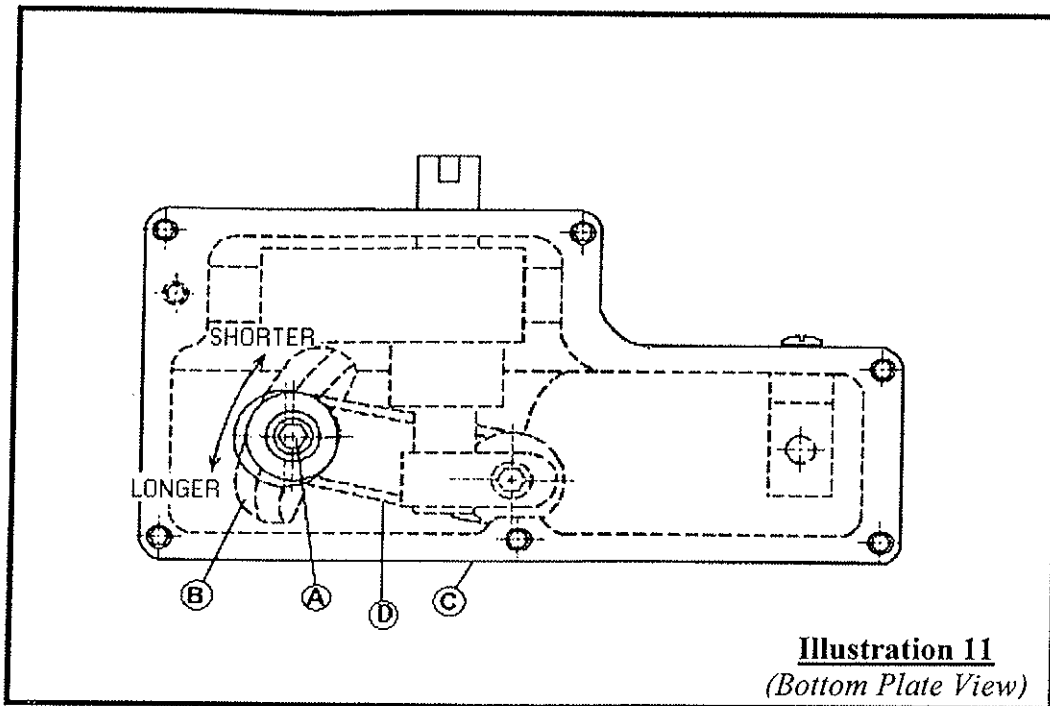

Illustration 11
(Bottom Plate View)

The standard factory setting of the stitch length is 3/8" (10 mm per stitch). Other stitch lengths can be set according to customer requirements. If a change is needed, please follow the procedure below:

1. Be sure the feed dog is down below the surface of the throat plate, by rotating the drive pulley clockwise. (**Illustration 12**)
2. Stand the sewing head on its drive pulley so that no oil can flow out when removing the bottom cover (**C, Illustration 5 and 11**). Block the head to prevent it from rotating on its pulley.
3. Remove the oil drain plug (**Illustration 11**) from the bottom cover (**C**). The drain hole will provide access to the socket cap screw (**A**), used in adjusting the stitch length.
4. With a 3/16" allen wrench, loosen (**but do not remove**) the socket cap screw (**A**) (#SC142878). (**Illustration 11**) The screw may fall into the housing if it is removed.
5. The stitch length is changed by moving link (**D**) (**Illustration 11**) along the slot in link (**B**). *Moving link (**D**) toward the throat plate shortens the stitch. Moving it away from the throat plate lengthens it.*
6. Tighten the socket cap screw (**A**), but not fully yet.

**FISCHBEIN® MODELS 200 & 201 EMPRESS™ SERIES SEWING HEAD
OPERATOR'S MANUAL**

7. To check the stitch length, tilt the sewing head enough to rotate the drive pulley, without allowing the oil to leak out of the drain hole. Put a sample piece of bag under the presser foot. Rotate the drive pulley clockwise through ten cycles and remove the bag sample. Calculate the stitch length and make necessary adjustment to the socket cap screw (A). (Section 3.14.3, page 37-38, #5)

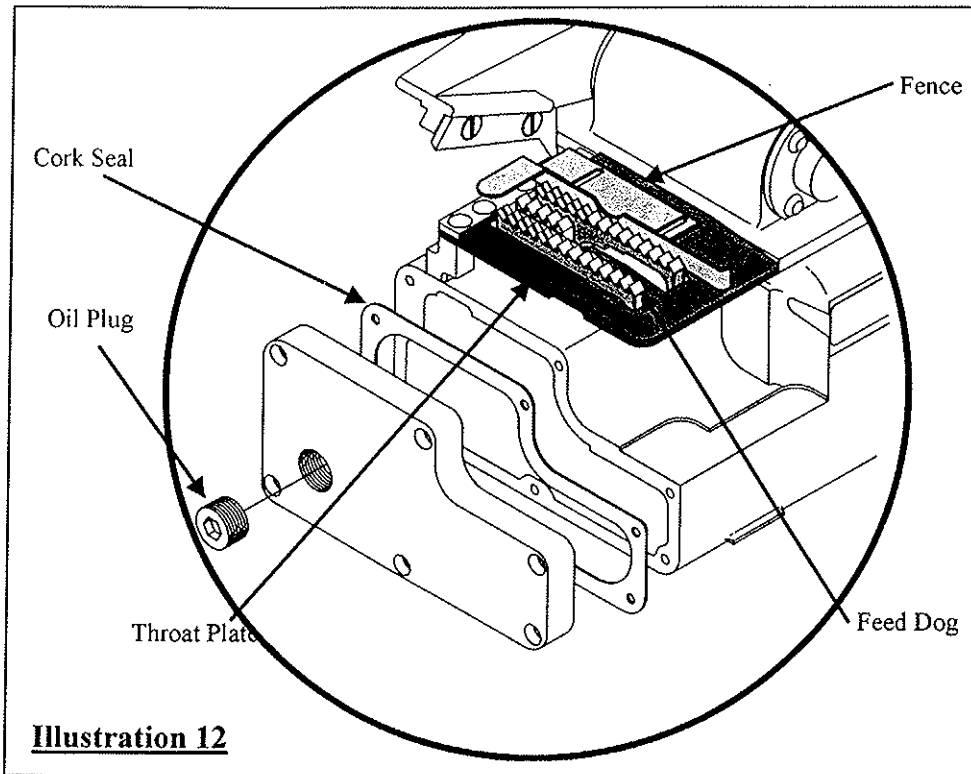

Illustration 12

8. Tighten socket cap screw (A) after obtaining a correct setting. Wrap new Teflon® tape around the drain plug, and install it back into place.
9. Stitch length can vary between 2 to 4 stitches per inch (6,4 mm to 12,7 mm per stitch).
10. Changing the stitch length also involves re-synchronising the sewing head to the conveyor and the infeed (see Section 3.14, page 34).

3.4 CORK SEAL REPLACEMENT

1. Referring to **Illustration 11 and 12**, check the cork seal located between plate (C) and housing (D), whenever plate (C) is removed.
2. Replace the seal (part number 10093) if it is damaged. Grease can be applied.

3.5 NEEDLE REPLACEMENT

1. Refer to **Illustration 13**. Loosen hex head screw (A) and remove the needle (B).
2. Install the new needle with the flat side (C) toward the hex head screw (A).
3. Be sure the new needle is inserted into the needle chuck (D) as far as it will go.
4. Tighten the hex head screw (A).
5. Follow **Sections 3.9.1-5 and 8, page 22** to properly set the needle in place.

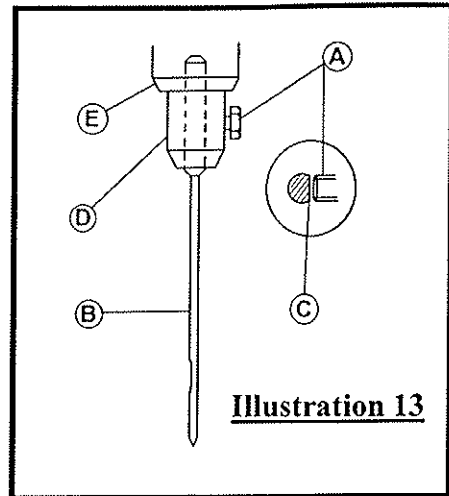

Illustration 13

3.6 FEED DOG REPLACEMENT

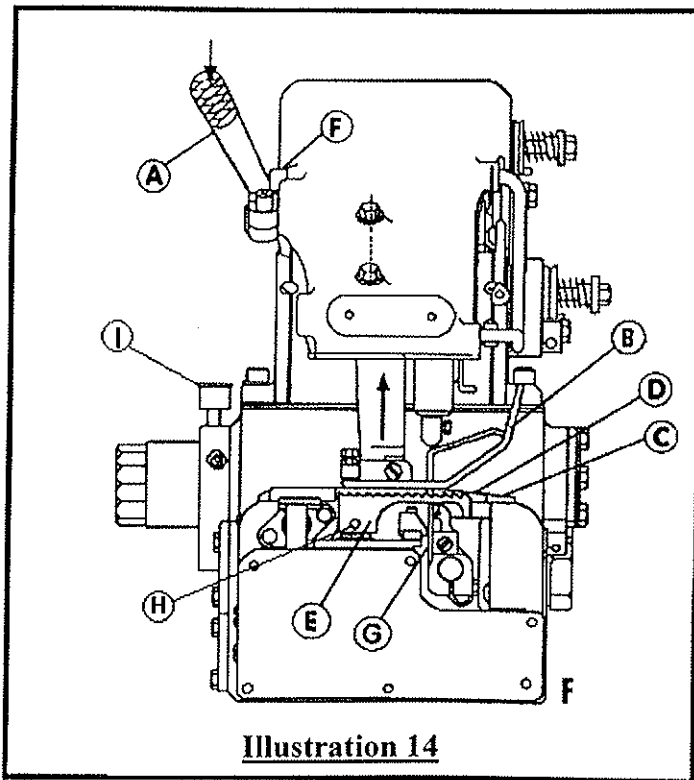

Illustration 14

1. Lock out compressed air and electrical power so the machine cannot run. (**Illustration 14**)
2. Press lever (A) toward the oil pressure gauge (I). This will move the presser foot (B) upward and away from the throat plate (D).
3. Put a ¼" (6mm) spacer (not provided) between lever (A) and screw (F).
4. Follow the instructions in **Section 3.5 NEEDLE REPLACEMENT** and remove the needle.
5. Remove the throat plate (D) by removing screws (C).
6. Loosen screw (H) and remove the feed dog (E).
7. Install the new feed dog (E). Be sure the feed dog is seated all the way down on the shaft then tighten screw (H). Refer to **sections 3.9.6 and 7, page 25** for the adjustment sequence.
8. Re-assemble in reverse sequence.
9. Remove the ¼" (6mm) spacer from between lever (A) and screw (F).

3.7 THROAT PLATE REPLACEMENT

1. Refer to **Illustration 14**. Lock out compressed air and electrical power so the machine cannot run.
2. Press lever (A) toward the oil pressure gauge. This will move the presser foot (B) upward and away from the throat plate (D).
3. Put a ¼" (6mm) spacer between lever (A) and screw (F).
4. Follow the instructions in section **3.5 NEEDLE REPLACEMENT**, page 20 and remove the needle.
5. Remove the throat plate (D) by removing screws (C).
6. Re-assemble the machine in the reverse sequence.
7. Check for proper alignment between the throat plate and the feed dog. (**Section 3.9.7, page 26**)
8. Remove the ¼" (6mm) spacer between lever (A) and screw (F).

3.8 PRESSER FOOT PRESSURE ADJUSTMENT

1. Refer to **Illustration 15**. Turn hex head screw (A) clockwise until it is tight.
2. Loosen the hex head screw (A), five turns and check the performance of the sewing head. **DO NOT REMOVE SCREW (A). DOING SO WILL RESULT IN THE SPRING ASSEMBLY (B) INSIDE THE HOOD (E) TO COME APART.**

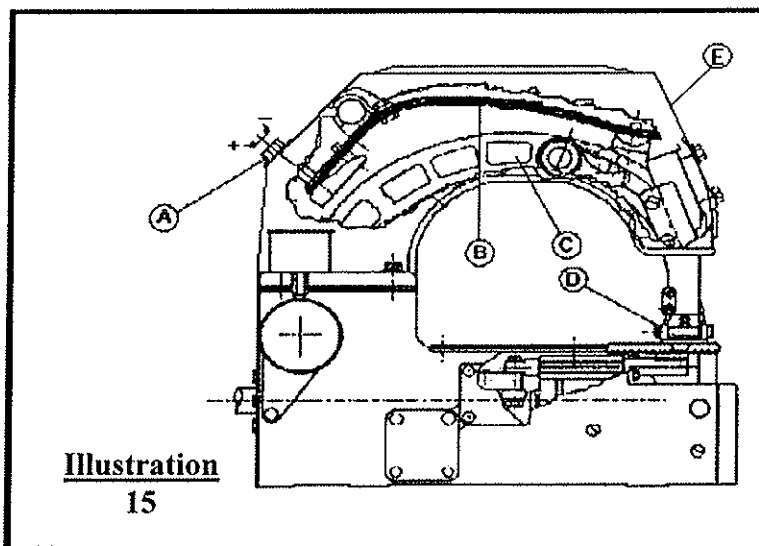

3. Further adjustment may be needed. Tighten screw (A) to increase the force exerted by spring (B) on lever (C) and, therefore, on presser foot (D). Loosening screw (A) will decrease the force exerted by spring.

3.9 FINE TUNING OF THE SEWING MACHINE

1. Presser foot adjustment:

NOTE: This adjustment is to be done without bag or tape in the sewing head.

1. Refer to **Illustration 16**. The presser foot (**B**) should not be parallel with the throat plate (**D**). There must be a small gap (**t**) at the infeed end of the presser foot.
2. Gap (**t**) is adjusted by turning hex head screw (**E**), after unlocking the screw with nut (**F**). Gap (**t**) should be 0.012" (0,3mm). Gap (**t**) is increased by turning screw (**E**) clockwise, and decreased by turning screw (**E**) counterclockwise.

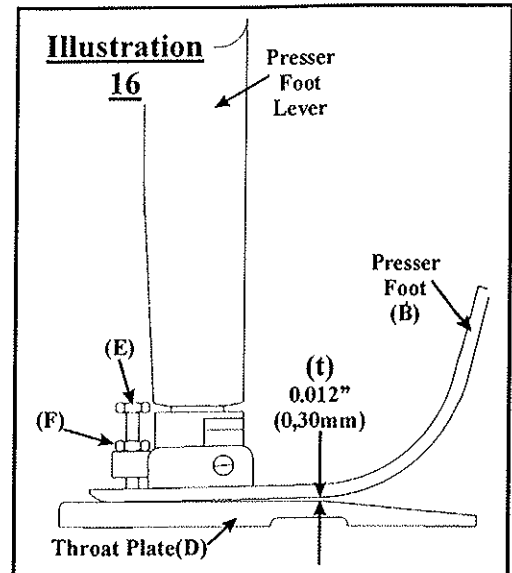

2. Needle and needle guide adjustment:

1. Refer to **Illustration 17**.
2. Press lever (**A**) toward the oil pressure gauge (**I**). This will move the presser foot (**B**) upward and away from the throat plate (**D**).
3. Remove presser foot (**B**) by loosening screw (**G**).
4. Remove throat plate (**D**).
5. Remove feed dog (**E**).
6. The machine then appears as in **Illustration 14**.
7. Adjust the distance between needle guide (**I**) and needle (**D**)
See **Illustration 19**.

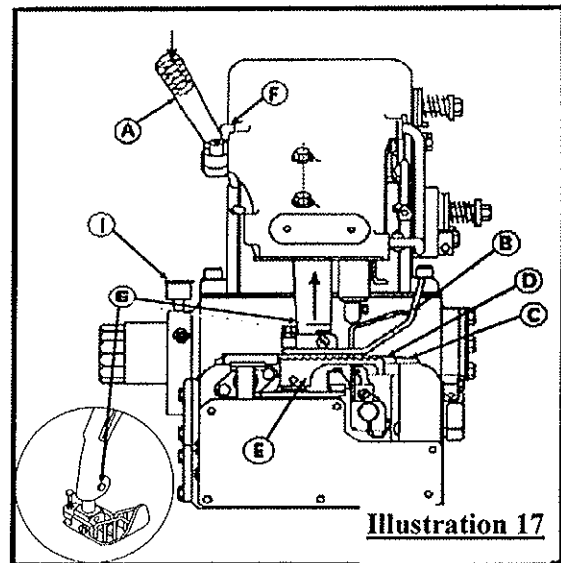

**FISCHBEIN® MODELS 200 & 201 EMPRESS™ SERIES SEWING HEAD
OPERATOR'S MANUAL**

Always use a new needle before starting to adjust the machine.

8. Refer to **Illustration 19**. Loosen cap screw (J). Move the needle guide to achieve a gap of 0.008" (0,2mm) between the needle (D) and needle guide (I).
9. Tighten cap screw (J) after the gap adjustment is completed.

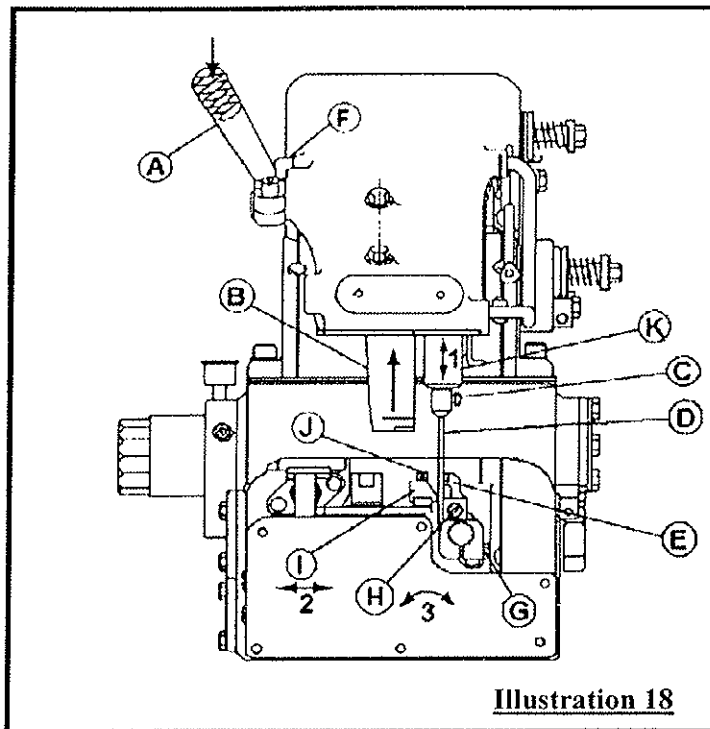

Illustration 18

WARNING: ALWAYS USE RECOMMENDED TOOLS.

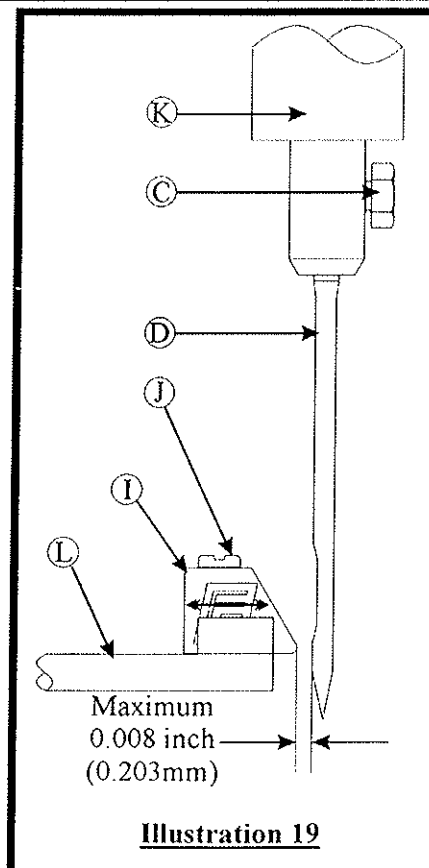
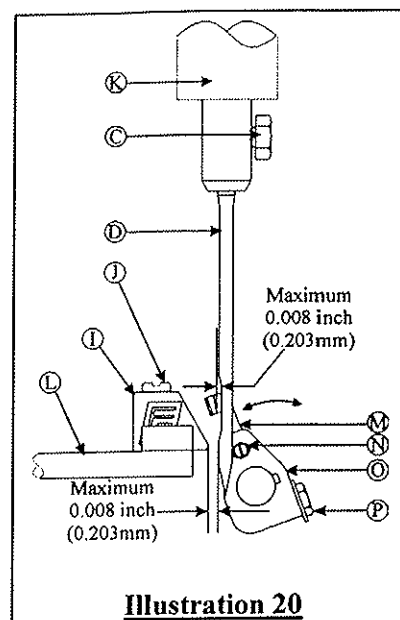

Illustration 19

3. Needle and Loper Clearance

1. Refer to **Illustration 20**. It is very important that the needle (**D**) and the looper (**M**) do not touch during the forward movement of the looper (**M**).
2. With the looper (**M**) at the full forward position, adjust the looper (**M**) as close as possible with a maximum 0.008" (0,2mm) gap between the needle (**D**) and looper (**M**). Loosen screw (**N**) and move the looper (**M**) to provide the gap.
3. Tighten screw (**N**) and re-check the gap.



4. Approximate setting of the distance between needle and looper

1. Refer to **Illustration 21**. Turn the machine and look from the feed side.
2. For adjustment of the distance **X**, we use the adjusting Gauge (part #10230) (**F** in **Illustration 22**) adjust the distance **X**. See **Section 3.13** for more about the Gauge.
3. This distance is set as the looper (**B**) has reached the end of its backward travel. If this distance is not correct (see **Illustration 22 and 23**), loosen the screw (**D**). The looper holder (**C**) can be moved along its shaft (**E**) in a longitudinal direction.

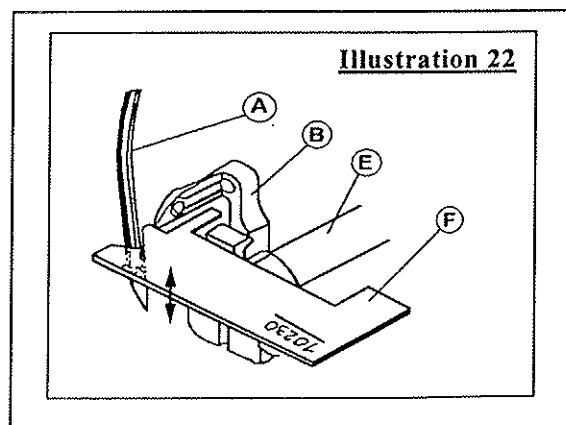
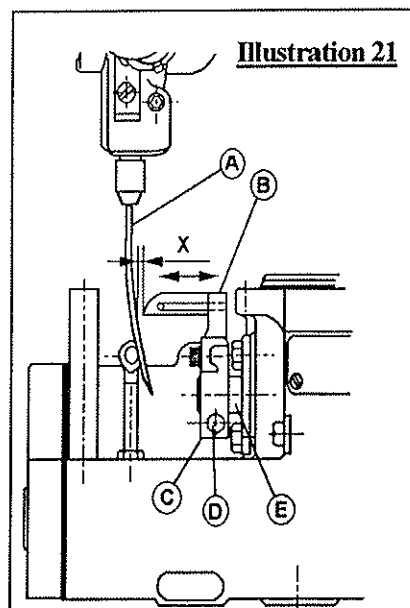

4. Once the correct distance for **X** is achieved, tighten screw (**D**).

**FISCHBEIN® MODELS 200 & 201 EMPRESS™ SERIES SEWING HEAD
OPERATOR'S MANUAL**

5. Fine tuning the distance between the needle and the looper

1. Refer to **Illustration 23**. Check to see if the hole in the looper (**B**) lines up with the slot in the needle (**A**) by rotating the drive pulley (not shown). This should be checked with the needle (**A**) in front of the looper (**B**) as well as behind it.
2. If the hole and slot do not line up, perform the adjustments described in **section 3.13** while referring to **Illustrations 34 and 36**.
3. After the adjustments are made, re-check to see if the slot and hole line up.

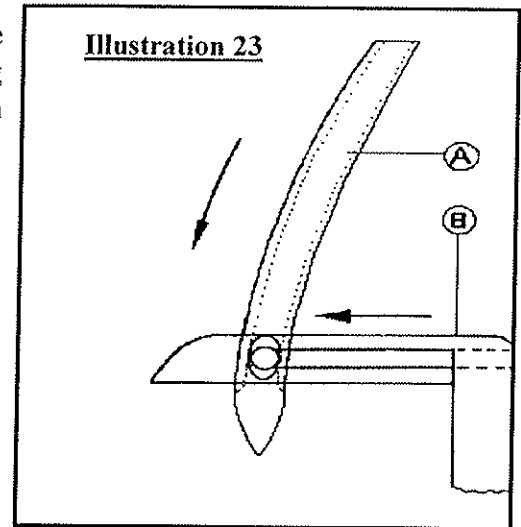

6. Feed dog height adjustment

Perform this adjustment inside the machine at the feed dog clamp. To adjust the height, move shaft up or down.

1. Refer to **Illustration 24**. Rotate the drive pulley (not shown) until the feed dog (**C**) is in the uppermost position. The feed dog (**C**) must protrude above the throat plate (**B**) the thickness of gauge (**A** – part number 10230).
2. If the feed dog (**C**) is not properly adjusted, refer to **Illustration 25**. Remove the housing cover (**A**), after setting the sewing head on the drive pulley to prevent the oil from leaking
3. Loosen cap screw (**B**), and move the feed dog shaft (**C**) up or down until the feed dog (**C** in **Illustration 24**) is the thickness of the gauge (**A** in **Illustration 24**) above the throat plate (**B** in **Illustration 24**).
4. Check the feed dog and throat plate alignment. (**Section 3.9.7, page 26**)
5. Tighten cap screw (**B**), and replace the housing cover (**A**).

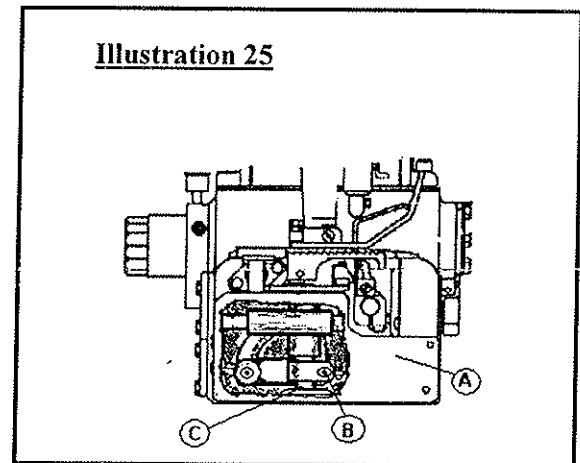
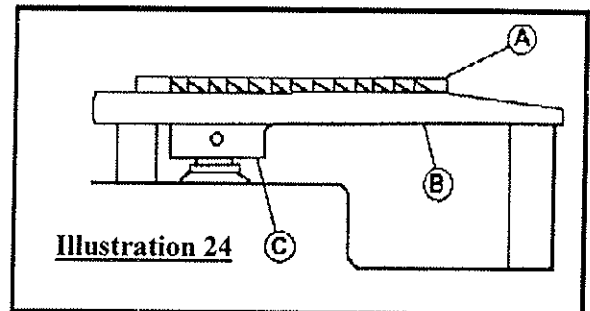

7. Feed dog parallel to the throat plate adjustment

1. Refer to **Illustration 26**. Look at feed dog (C) from the top. The sides of the feed dog (C) must be parallel to the sides of the slots in throat plate (B).
2. If the sides of the feed dog are not parallel to the throat plate, refer to **Illustration 25**. Remove the housing cover (A), after setting the sewing head on the drive pulley (up side down) to prevent oil from leaking.

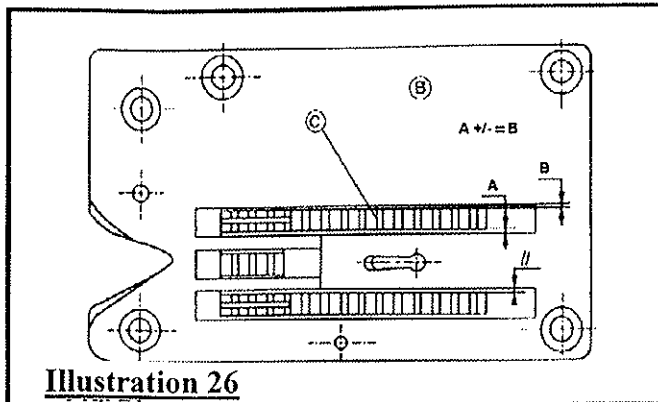

3. Loosen cap screw (B), and rotate the feed dog shaft (C) until the sides of the feed dog (C in **Illustration 26**) are parallel to the slots in the throat plate (B in **Illustration 26**).

4. Check the feed dog height. (**Section 3.9.6, page 25**)
5. Tighten cap screw (B), and replace the housing cover (A). (**Illustration 25**)

8. Needle holder adjustment

The correct setting is fixed at the factory. Do not remove the needle holder (C, **Illustration 27**) from the needle lever (E) if this is not necessary.

If it is necessary to replace the needle holder (C), follow these steps:

1. Refer to **Illustration 27**. Remove the needle (D) from the needle holder (C) by loosening hex head screw (B).
2. Remove needle holder (C) from the needle lever (E) by loosening hex head screw (A).
3. Measure the length X of the needle holder as shown in **Illustration 28**.
4. Set the new needle holder to the same length X and lock into position with the lock nut.
5. Place the new needle holder (C) in the needle lever (E).

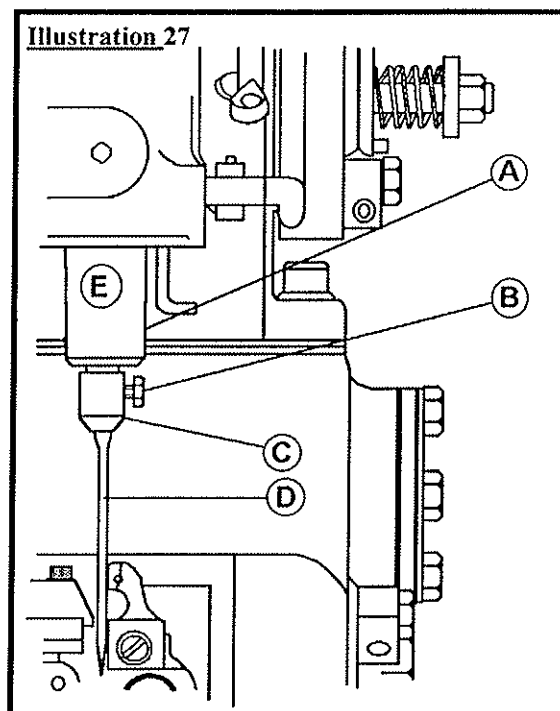

**FISCHBEIN® MODELS 200 & 201 EMPRESS™ SERIES SEWING HEAD
OPERATOR'S MANUAL**

6. Refer to **Illustration 29**. Check the parallelism of the new needle holder (**D**) using the gauge (**F**) (part # 10230) where it is parallel to the front edge of the throat plate. Press the gauge flat against the screw (**E**).
7. If the needle holder (**D**) is not parallel, loosen screw (**A**) in **Illustration 27**, and rotate the needle holder (**C**) until it is parallel.
8. Tighten screw (**A**).

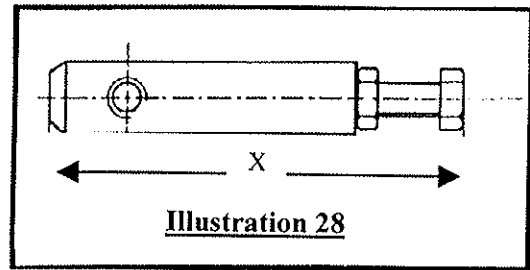
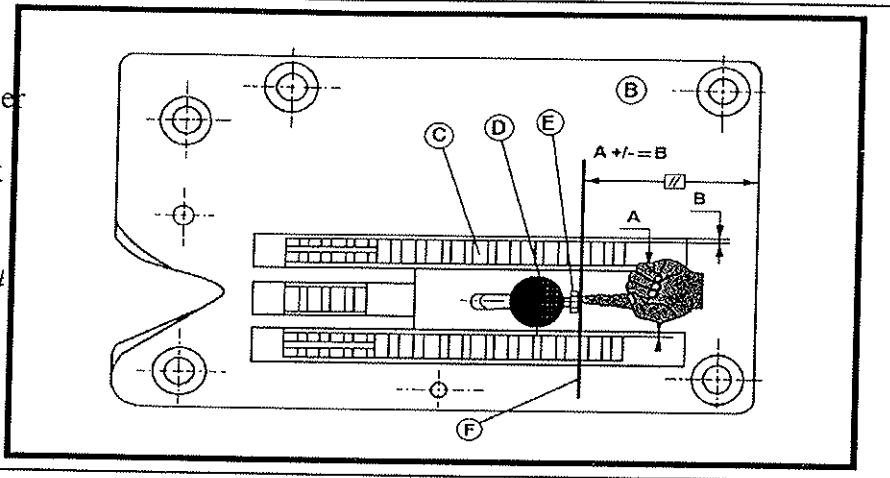

Illustration 29

- D = needle holder
E = screw to lock needle
F = Gauge (part # 10230)



3.10 TAPE/THREAD CLIPPER ADJUSTMENT (*Model 201 only*)

NOTE: Refer to **Illustration 30**. Anytime an adjustment or replacement is made to the clipper knives, feed dog or throat plate, locknut (A) must be loosened so that set screw (B) can be turned clockwise until the stationary blade and the moving blade separate.

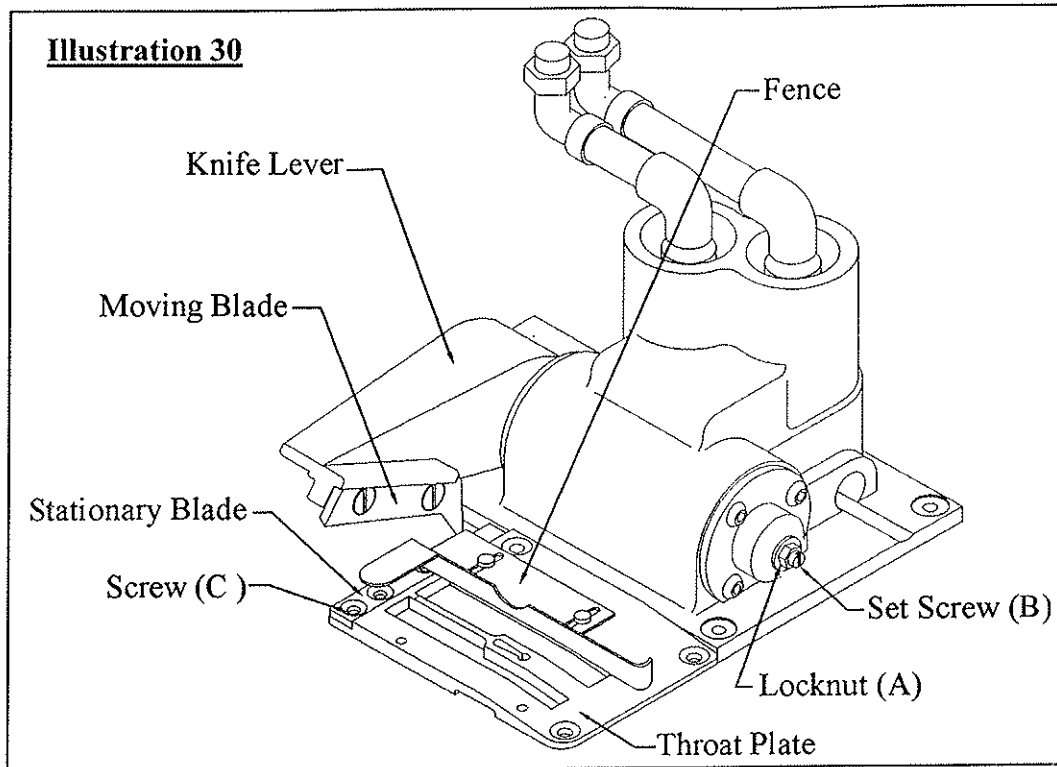

1. Refer to **Illustration 30**. To adjust the stationary blade, first remove the fence from the throat plate and then loosen screw (C). Adjust the stationary blade so that it is parallel to the moving blade along the full length of the blades. This will allow good shearing action.
2. When the clipper air is on and the knife completely open, the extension on the moving blade should be flush with the bottom of the stationary blade.
3. After making any adjustment or replacement, be sure set screw (B) has been turned counterclockwise until the stationary blade and the moving blade have made firm contact and locknut (A) has been re-tightened.

3.11 TAPE / THREAD CLIPPER BLADE REPLACEMENT ***(Model 201 only)***

NOTE: Exercise great care while working with the blades and wear proper eye, foot and hand protection.

1. Lock out compressed air and electrical power so the machine cannot run.
2. Refer to **Illustrations 30**. Loosen lock nut (A), and turn clockwise set screw (B) to separate blades.
3. Remove knife lever and change moving blades. Make sure the flat head screws are below the blade surface when tightened.
4. Remove the fence from throat plate and change the stationary blade. Tighten the stationary blade fasteners.
5. Turn set screw (B) counterclockwise until it is not contacting the end of the knife shaft. The screw will feel loose or free in the threads.
6. Turn set screw (B) clockwise until it touches the end of knife shaft. A slight resistance will be felt.
7. After the screw touches, turn clockwise one additional turn.
8. Turn on the compressed air to the clipper unit, and install the knife against the stationary blade. Align the moving blade extension with the bottom (backside) of the stationary blade.
9. Tighten the knife lever bolts.
10. With the compressed air to the clipper turned off, push knife lever to its closed position.
11. With screw (C) snug, make the stationary blade parallel with the moving blade. Move the stationary blade side to side at screw (C).
12. Back off set screw (B) and tighten lock nut (A). Set screw (B) should not contact knife shaft during clipper operation.
13. Tighten all screws and replace fence.
14. The tape clipper works best with a minimum 90 PSI (6 bar).
15. A small amount of oil or grease on the moving blade extension is recommended to provide smooth operation.

3.12 MOUNTING & ADJUSTING THE ROTARY AIR KNIFE (Model 200 only)

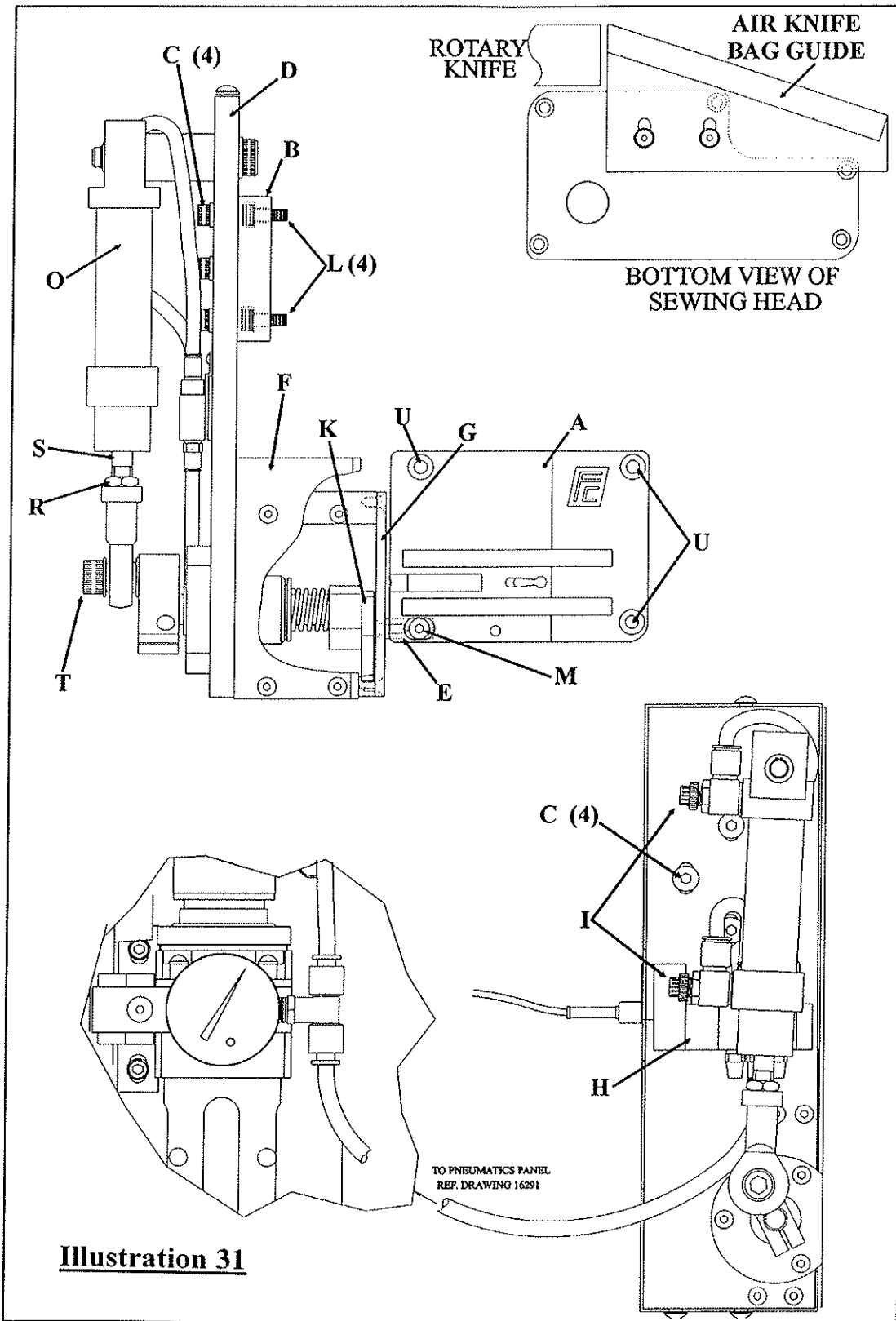

Mounting the Air Knife

1. Refer to **Illustration 31**. Mount the modified throat plate (A) to the sewing head using the original three flat head screws through three of the holes (U).
2. The mounting block (B, **Illustration 31**) is mounted to the outside face of the pivot knife bracket (**Illustration 32**) on the side of the housing. The four original screws are removed and replaced with four 10-32 x 7/8" cap screws (L, **Illustration 31**).
3. The knife assembly is mounted to the block (B) with four M6 metric cap screws (C) through the slotted holes in the support plate (D). **NOTE: The air cylinder (O) will have to be removed to gain access to all four screws (C). The cylinder (O) can be moved by removing cap screw (T). The slots provide for vertical adjustment for the assembly. These screws only need to be finger tight initially.**
4. Move the throat plate mounting block (E, **Illustrations 31 and 33**) until it touches the back of the throat plate. Move the assembly up and down until the tapped hole in the mounting block (E) lines up with the countersunk slot in the throat plate (A). Secure with an M4 metric flat head screw (M).
5. Tighten the four M6 socket head cap screws (C) and replace the air cylinder (O).
6. Remove the side cover (F) and tighten the M4 metric flat head screw (W) that secures the mounting block (E) to the fixed knife blade (G). (**Illustrations 31 and 33**)
7. Replace the cover (F).

NOTE: The coil of the solenoid valve (H) is 110VAC.

8. Mount the outer cover on the rotary air knife assembly.

Adjustments and Maintenance

1. A regulator/filter assembly is required and is offered as an option. The air pressure to the air knife must be 80 PSI (5,5 bar) minimum.
2. If the thread is not cut off cleanly, it is usually the result of a dull knife set or a maladjusted fixed knife blade (G).
3. Adjust the flow control valves (I) on the air cylinder (O) to provide a smooth operation of the air knife. Turning out (counterclockwise) the adjustment screw on the valve will increase the speed of the air knife. The valves (I) are adjusted at the factory for maximum air flow and the fastest cut.

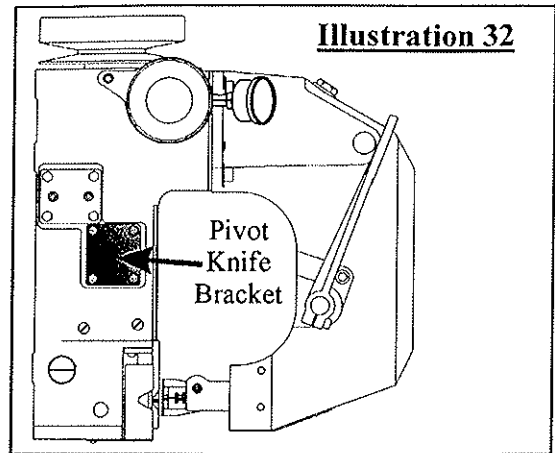

4. To replace the blades, first remove the side cover (F). Remove screws P and W to remove the fixed blade. Remove screws V. Replace the old blades with new. (#31112 and #31113)
5. The cutting edges of the fixed blade (G) and movable blade (K) must contact each other. If they do not, the cut edges of the thread will be frayed, or the thread will not be cut completely through. The four M4 set screws (J) provide this adjustment. (Illustration 33) Three are in the fixed blade (G), and one is in the lower fixed blade bracket (Q). Adjust the screws (J) until there is contact between the cutting edges. There may be a small gap along the back edges of the two knife blades as a result.
6. The contact between the two knives should periodically be coated with a light layer of grease. Wheel bearing grease is used at the factory.
7. The tip of the movable knife blade (K) must not extend beyond the cutting edge of the fixed knife blade (G). If it does, loosen nut (R) on the air cylinder (O). The air cylinder (O) must be in the retracted position as shown in Illustration 31. Screw the shaft (S) of air cylinder (O) in or out until the tip of the movable knife is retracted beyond the cutting edge of the fixed blade (G).

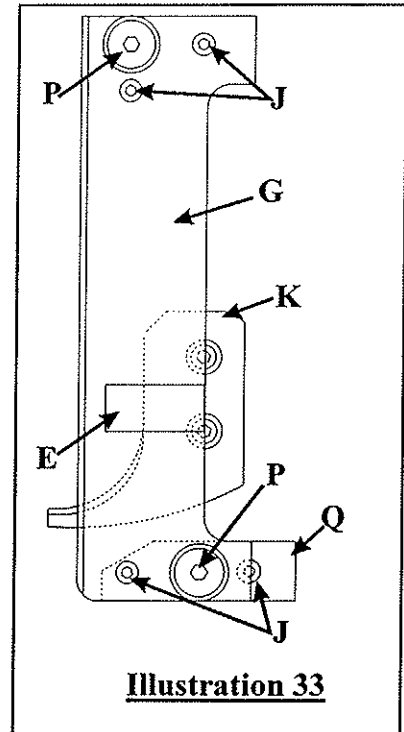

8. Further assistance is available from your Fischbein representative or by calling the Technical Service Department at the Fischbein Company. (page 2)

**FISCHBEIN® MODELS 200 & 201 EMPRESS™ SERIES SEWING HEAD
OPERATOR'S MANUAL**

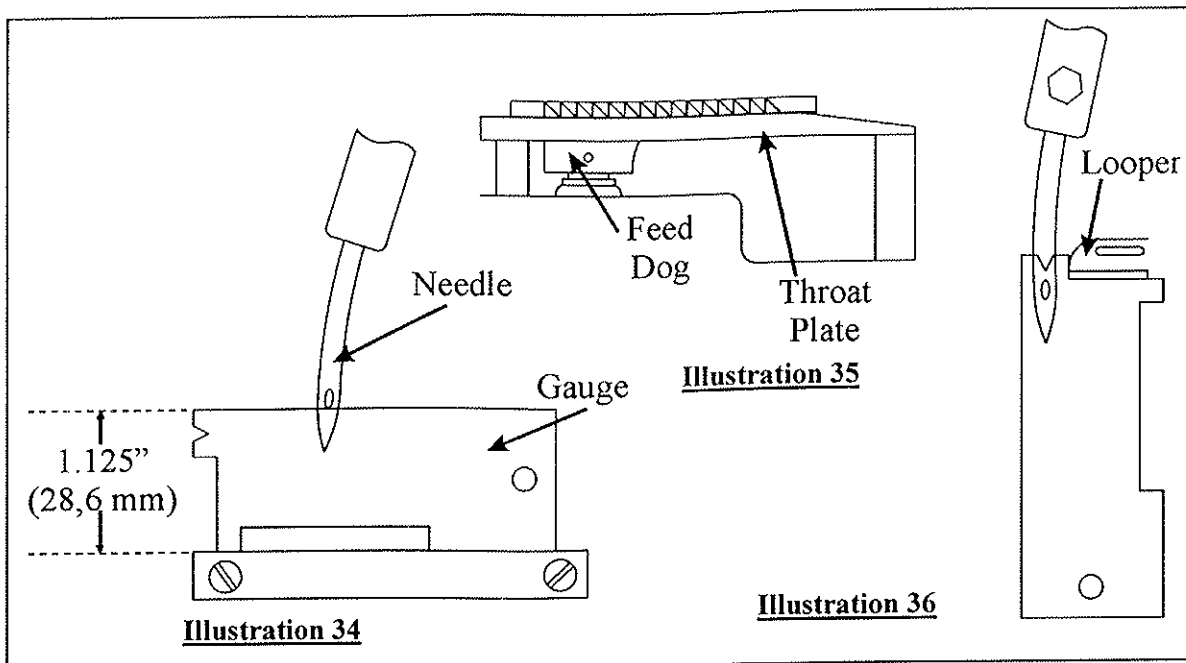

3.13 USING THE GAUGE

The gauge is a necessary tool for adjusting Models 200 and 201. The following should be used as a reference for your machine. The gauge (part # 10230) has three important dimensions for three separate measurement functions.

1. The thickness of the gauge is 1/16" (1,6mm). It is used to check the height of the feed dog above the throat plate at the top of the stroke (see **Illustrations 35**). The measurement is made with the presser foot on the machine and no thread or tape between the foot and the feed dog. The gauge should just fit between the plate and presser foot. If it does not fit, the feed dog should be checked for wear and replaced if needed. If the feed dog is not worn then adjust to the 1/16" (1,6mm) height.
2. Standing the gauge on edge, check the height of the needle at the top of its travel. The needle height should be 1-1/8" (28,6mm). Refer to **Illustration 34**. The throat plate must be on the machine for this check because the measurement is made from the throat plate to the bottom of the eye of the needle. This dimension is very critical. Follow the adjustments in section **3.9.8 NEEDLE HOLDER ADJUSTMENT (page 26)**, if this dimension is not correct. Be sure the needle is in the chuck all the way. The cut away portion, 1/4" x 1-3/8" (6mm x 35mm), allows this check to be made when the feed dog is on the machine. The needle and feed dog will be at the top of the stroke at this point.
3. The third use of the gauge is to check the stroke or timing of the looper relative to the needle. Refer to **Illustration 36**. With the looper to the right of the needle as far as it will travel or with the looper retracted into the machine as far as it will go, measure from the center of the needle to the tip of the looper. The small "V" in the gauge is now placed on the needle. The looper can be adjusted so the gauge clears the looper and that the looper is right up to the gauge. Follow the adjustments in section **3.9.5 FINE TUNING THE DISTANCE BETWEEN THE NEEDLE AND THE LOOPERS (page 25)**, if this dimension is not correct.

Other uses for the Gauge:

The gauge is exactly 3" long at the longest point. This can be used as a gauge to measure stitch length.

The gauge is also a good straight edge to check the rotation of the needle chuck. It should be parallel with the machine. To check, place it on the needle clamping screw. When held firmly on the screw, it should seek a straight line parallel with the machine. (Section 3.9.8, page 26)

3.14 SEWING HEAD SPEED ADJUSTMENT AND SYNCHRONIZATION WITH THE SYSTEM

3.14.1 CALCULATING CONVEYOR SPEEDS

When calculating speeds for production rates, keep the following in mind:

- One revolution of the sewing head equals one stitch.
- The speed of the sewing head needs to be 2% faster than the conveyor that carries the product to it. This is desired because the sewing head needs to pull the bag taut through the infeed. **NOTE:** The maximum RPM of the Model 200 and 201 sewing heads is 2600 RPM.
- The speed of the infeed should match the speed of the conveyor.
 - Key information to be gathered:
 - 1) Process speed (number of bags/min)
 - 2) Speed of the conveyor designated to carry bags to the sewing system
 - 3) Desired or required space between bags (often dictated by other equipment such as weighing and filling)
 - 4) The number of stitches required on the closure

NOTE: Generally, it has been observed that a slight change in the density of the contents, does not necessarily affect the production rate.

**FISCHBEIN® MODELS 200 & 201 EMPRESS™ SERIES SEWING HEAD
OPERATOR'S MANUAL**

Example 1: (English)

A conveyor working at 67 FPM, with a bag closure of 2.5 stitches/inch, will require the following RPM:

$$\begin{aligned} \text{2\% increase:} & \quad 67 \text{ ft/min} \times 1.02 = \mathbf{68.34 \text{ ft/min}} \text{ (sewing head linear rate)} \\ \text{Conversion:} & \quad 2.5 \text{ stitches/inch} \times (12 \text{ inches/ft}) = 30 \text{ stitches/ft} = \mathbf{30 \text{ rev/ft}} \\ & \quad \text{(Note: 1 rev produces 1 stitch)} \\ \text{Sewing Head RPM:} & \quad (68.34 \text{ ft/min}) \times (30 \text{ rev/ft}) = 2050 \text{ rev/min} = \mathbf{\underline{2050 \text{ RPM}}} \end{aligned}$$

Example 2: (Metric)

A conveyor working at 25 m/min, with a stitch length of 10 mm/stitch, will require the following RPM:

$$\begin{aligned} \text{2\% increase:} & \quad 25 \text{ m/min} \times 1.02 = \mathbf{25,5 \text{ m/min}} \text{ (sewing head linear rate)} \\ \text{Conversions:} & \quad \Rightarrow 25,5 \text{ m/min} \times (1000 \text{ mm/m}) = \mathbf{25\,500 \text{ mm/min}} \\ & \quad \Rightarrow 10 \text{ mm/stitch} = \mathbf{10 \text{ mm/rev}} \text{ (Note: 1 rev produces 1 stitch)} \\ \text{Sewing head RPM:} & \quad (25\,500 \text{ mm/min}) / (10 \text{ mm/rev}) = 2\,550 \text{ rev/min} = \\ & \quad \mathbf{\underline{2550 \text{ RPM}}} \end{aligned}$$

Example 3: (Using the English Speed Charts)

A conveyor working at 65 FPM, with a bag closure of 2.5 stitches/inch, requires the following RPM:
Looking at the English speed charts (Page 39) under 2.5 stitches/inch and across from 65 FPM, yields 1950 RPM. Allowing for the 2% additional RPM sewing head speed provides the final speed of $(1950 \text{ RPM} \times 1.02) = \mathbf{1989 \text{ RPM}}$.

Example 4: (Using the Metric Speed Charts)

A conveyor working at 24 m/min, with a stitch length of 10,0 mm/stitch, requires the following RPM:
Looking at the Metric speed charts (Page 40) under the 10,0 mm/stitch and across from the 24 m/min, yields 2400 RPM. Allowing for the 2% additional sewing head speed provides the final speed of $(2400 \text{ RPM} \times 1.02) = \mathbf{2448 \text{ RPM}}$.

3.14.2 BAG HANDLING CAPACITY

The bag speed in English units of any Fischbein system can be determined by multiplying stitches per inch by 12 to determine stitches per foot, and then dividing the maximum sewing rate by that figure. For example:

$$\begin{aligned} & 1900 \text{ RPM (sewing rate)} / (2.5 \text{ stitches per inch} \times 12 \text{ inches/ft}) = \\ & \quad \mathbf{\underline{63.33 \text{ linear feet per minute}}} \end{aligned}$$

FISCHBEIN® MODELS 200 & 201 EMPRESS™ SERIES SEWING HEAD
OPERATOR'S MANUAL

The bag speed in Metric units can be determined by dividing the stitch length by 1000 and then multiplying this quantity by the sewing rate. For example:

$$2300 \text{ RPM (sewing rate)} \times (10 \text{ mm/stitch} / 1000 \text{ mm/m}) =$$

23 linear meters per minute

It is possible to calculate the actual production rate in bags per minute by establishing the width of each bag and the between-bag spacing on the conveyor. A minimum of 2.5 inches (64 mm) between bags is recommended for plain sewing. Therefore, for an 18 inch (457,2 mm) wide plain sewn bag with 2.5 inches (64 mm) spacing, each bag accounts for 20.5 inches (520,7 mm) of linear space. Referring back to the above two examples:

English: $(63.33 \text{ ft/min}) / \{(20.5 \text{ inches/bag}) / (12 \text{ inches/ft})\} = \underline{\underline{37.07 \text{ bags / min}}}$

Metric: $(23 \text{ m/min}) / \{(520,7\text{mm/bag}) / (1000 \text{ mm/m})\} = \underline{\underline{44,17 \text{ bags / min}}}$

An additional **10%** loss should be allowed for interruptions such as inspections or maintenance issues with the production line, which would still allow closure of:

English: $37.07 \text{ bags/min} - 3.707 \text{ bags/min} = \underline{\underline{33 \text{ bags per minute}}}$

Metric: $44,17 \text{ bags/min} - 4,417 \text{ bags/min} = \underline{\underline{39 \text{ bags per minute}}}$

3.14.3 SYNCHRONIZING THE SEWING SYSTEM

In order to produce good bag closures, a sewing system must be properly synchronized with the production line in which it operates. The synchronization is achieved by properly timing three different elements: (1) the bag transport conveyor, (2) the sewing system infeed and (3) the sewing head.

The conveyor and the infeed will be synchronized to travel at the same speed. This will prevent bags from skewing forward or backward as they travel into the sewing system.

The sewing head requires that it be set up to run a speed slightly faster than the infeed and the conveyor, typically about **2%** faster. The sewing process requires that the bag be pulled taut to produce a stitching pattern that is smooth and flat.

The sewing head, the infeed and the bag transport conveyor can be adjusted to produce the proper set up for a variety of applications. Please consult your Fischbein distributor for the proper set up or call Fischbein directly.

**FISCHBEIN® MODELS 200 & 201 EMPRESS™ SERIES SEWING HEAD
OPERATOR'S MANUAL**

1. The speed of the bag transport belt is measured in feet per minute (meters per minute).
2. The sewing head is equipped with a variable pitch pulley. The two sections of the pulley can be rotated relative to each other in ¼ turn increments. (**Illustration 37**)
3. First loosen the two set screws "B" with an 1/8 inch allen wrench. The **quarter** turns are indicated by the notches "A" in the top of the pulley and change the speed of the sewing head by approximately **20 RPM**. By turning the top part of the pulley counterclockwise, the speed of the sewing head is increased (smaller pitch on pulley). If the pulley is turned clockwise, the speed is reduced. Once the adjustment has been made, be sure to tighten the set screws, but be careful to only tighten the screws down across from the notch locations. These notch locations not only mark quarter turns, but also indicate where flat sections exist in the threading of the pulley. If a screw is locked down in an area other than the flat areas, the threading on the pulley will be damaged and the pulley may not stay locked at this pitch.
4. The speed of the sewing head is measured in revolutions per minute (RPM) using a tachometer with a surface speed wheel tip to determine feet per minute (see **Speed Tables, pages 39 and 40**).

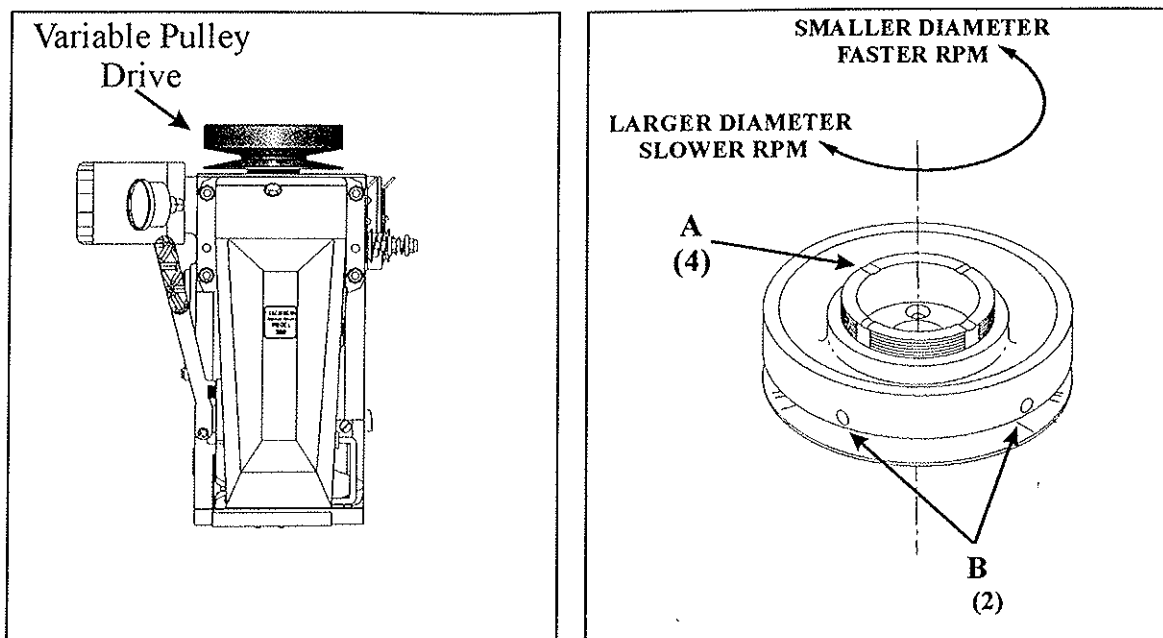

Illustration 37

5. In order to find out the stitch length, take a bag that has been stitched on the sewing head, with the individual thread facing forward. Measure the length of 10 stitches. In the **Illustration 38**, this length is 4" (101,6 mm).
English: This calculates to be $(10 \text{ stitches} / 4 \text{ inches}) = 2.5 \text{ stitches per inch}$.
Metric: This calculates to be $(101,6\text{mm} / 10 \text{ stitches}) = 10,16 \text{ mm per stitch}$.

**FISCHBEIN® MODELS 200 & 201 EMPRESS™ SERIES SEWING HEAD
OPERATOR'S MANUAL**

6. Adjust the speed of the sewing head so that it is 2% faster than the bag transport belt {e.g. transport belt 45 FPM (13,72 MPM) then the sewing head is to run at $(45 \text{ FPM} \times 1.02) = 45.9 \text{ FPM}$ (14 MPM)}.
7. If an infeed system is used, belts of the infeed must run at the same speed as the bag transport belt.

NOTES: Refer to **Illustration 37**. When adjusting the sewing head drive pulley, care should be taken so that the set screws are tightened against the flats of the pulley. Tightening the set screws against the threads can cause irreparable damage to the pulley.

The speed of a new or cold machine will be slower than one that is warm or has been operating in production for some time.

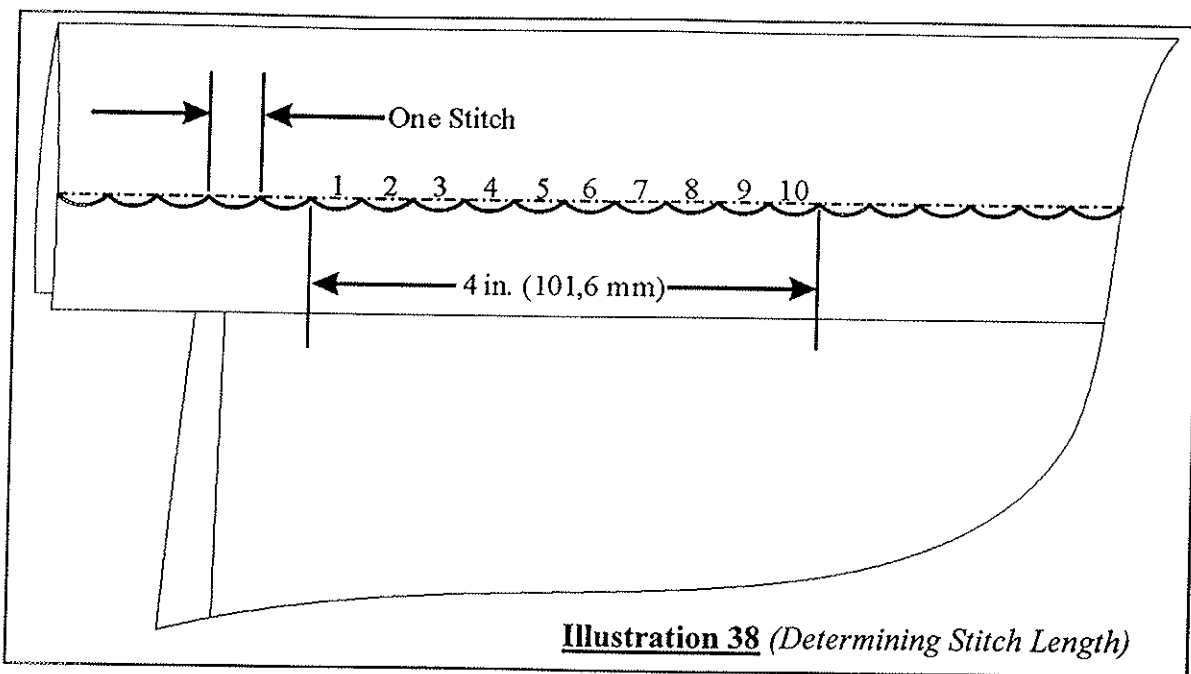

**FISCHBEIN® MODELS 200 & 201 EMPRESS™ SERIES SEWING HEAD
OPERATOR'S MANUAL**

4. SPEED TABLES

4.1 ENGLISH SYSTEM

FISCHBEIN EMPRESS™ 200 and 201 SEWING HEADS								
SPEED CHART (RPM) - ENGLISH SYSTEM								
		STITCH LENGTH (STITCHES PER INCH)						
		2	2.5	2.75	3	3.25	3.5	4
CONVEYOR SPEED (FPM)	30	720	900	990	1080	1188	1260	1440
	35	840	1050	1155	1260	1386	1470	1680
	40	960	1200	1320	1440	1584	1680	1920
	45	1080	1350	1485	1620	1782	1890	2160
	50	1200	1500	1650	1800	1980	2100	2400
	55	1320	1650	1815	1980	2178	2310	
	60	1440	1800	1980	2160	2376	2520	
	65	1560	1950	2145	2340	2574		
	70	1680	2100	2310	2520			
	75	1800	2250	2475				
	80	1920	2400					
	85	2040	2550					
	90	2160						
	95	2280						
100	2400							
105	2520							

**MAXIMUM
RPM: 2600**

4.2 METRIC SYSTEM

FISCHBEIN EMPRESS™ 200 and 201 SEWING HEADS													
SPEED CHART (RPM) - METRIC SYSTEM													
STITCH LENGTH (mm PER STITCH)													
		12,5	12,0	11,5	11,0	10,5	10,0	9,5	9,0	8,5	8,0	7,5	7,0
CONVEYOR SPEED (METERS PER MINUTE)	9	720	750	783	818	857	900	947	1000	1059	1125	1200	1286
	10	800	833	870	909	952	1000	1053	1111	1176	1250	1333	1429
	11	88	917	957	1000	1048	1100	1158	1222	1294	1375	1467	1571
	12	960	1000	1043	1091	1143	1200	1263	1333	1412	1500	1600	1714
	13	1040	1083	1130	1182	1238	1300	1368	1444	1529	1625	1733	1857
	14	1120	1167	1217	1273	1333	1400	1474	1556	1647	1750	1867	2000
	15	1200	1250	1304	1364	1429	1500	1579	1667	1765	1875	2000	2143
	16	1280	1333	1391	1455	1524	1600	1684	1778	1882	2000	2133	2286
	17	1360	1417	1478	1545	1619	1700	1789	1889	2000	2125	2267	2429
	18	1440	1500	1565	1636	1714	1800	1895	2000	2118	2250	2400	2571
	19	1520	1583	1652	1727	1810	1900	2000	2111	2235	2375	2533	
	20	1600	1667	1739	1818	1905	2000	2105	2222	2353	2500		
	21	1680	1750	1826	1909	2000	2100	2211	2333	2471			
	22	1760	1833	1913	2000	2095	2200	2316	2444	2588			
	23	1840	1917	2000	2091	2190	2300	2421	2556				
	24	1920	2000	2087	2182	2286	2400	2526					
	25	2000	2083	2174	2273	2381	2500						
	26	2080	2167	2261	2364	2476	2600						
	27	2160	2250	2348	2455	2571							
	28	2240	2333	2435	2545								
	29	2320	2417	2522									
	30	2400	2500										
	31	2480	2583										
	32	2560											

**MAXIMUM
RPM:2600**

5. OPENING A SEWN BAG

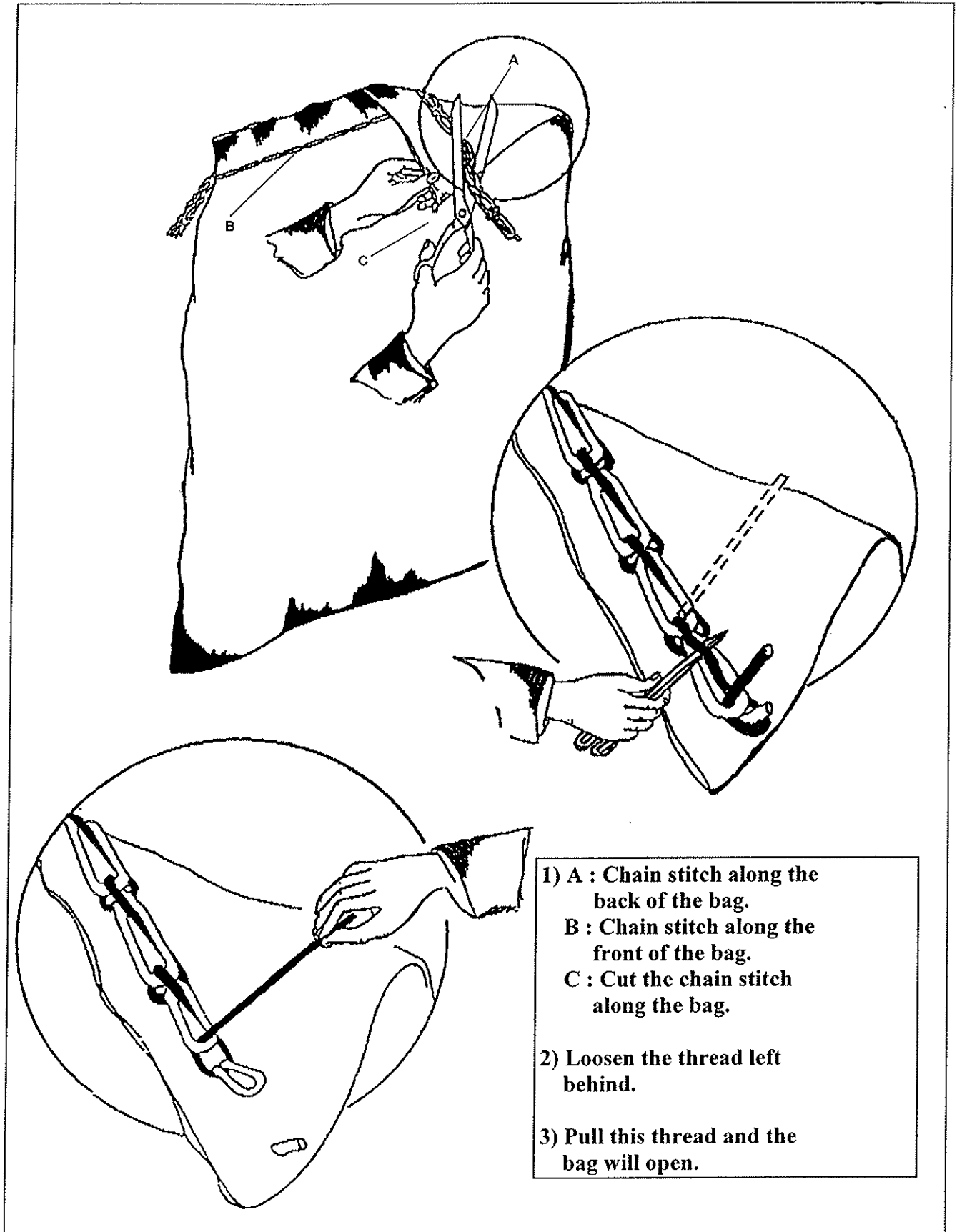

6. TROUBLESHOOTING

FAULT	CAUSE	SOLUTION
1. Machine runs but does not sew	<ol style="list-style-type: none"> 1. No thread. 2. Broken thread. 3. Broken needle. 4. Loose drive belt 	<ol style="list-style-type: none"> 1. Fit a new cone. 2. Re-thread sewing head. 3. Replace needle. 4. Tighten drive motor belt.
2. Poor quality chain stitch	<ol style="list-style-type: none"> 1. Thread is wrapped around guides or other object. 2. Poor thread tension. 3. Looper maladjustment. 4. Needle maladjustment. 5. Looper to needle maladjustment. 6. Needle guide maladjusted. 	<ol style="list-style-type: none"> 1. Remove the thread around the object and re-thread the sewing head. 2. Re-adjust thread tension. 3. Re-adjust looper. 4. Re-adjust needle. 5. Re-adjust the relationship between the looper and needle. 6. Re-adjust needle guide.
3. No chain stitch	<ol style="list-style-type: none"> 1. Bent needle. 2. Dull needle. 3. Poor thread tension. 4. Feed dog worn out. 5. Presser foot worn out. 	<ol style="list-style-type: none"> 1. Replace needle. 2. Replace needle. 3. Check thread tension. 4. Replace feed dog. 5. Replace presser foot.
4. Poor stitch	<ol style="list-style-type: none"> 1. Throat plate damaged. 2. Presser foot pressure incorrect. 3. Feed dog worn. 4. Thread tension poorly adjusted. 	<ol style="list-style-type: none"> 1. Replace throat plate. 2. Adjust pressure. 3. Replace Feed dog. 4. Adjust thread tension.
5. Thread constantly breaks	<ol style="list-style-type: none"> 1. Thread stuck or blocked around thread tensioners. 2. Thread tensioners maladjusted. 3. Needle worn or bent. 4. Looper worn or bent. 5. Throat plate worn or damaged. 6. Needle overheating. 7. Too much thread tension. 8. Poor quality thread. 	<ol style="list-style-type: none"> 1. Check thread guide or adjustment. 2. Readjust thread tensioners. 3. Replace needle. 4. Replace looper. 5. Replace throat plate. 6. Use another type of bag, a needle cooler or lubricated thread. 7. Less tension. 8. Use higher quality thread. (Fischbein lubricated thread)

**FISCHBEIN® MODELS 200 & 201 EMPRESS™ SERIES SEWING HEAD
OPERATOR'S MANUAL**

FAULT	CAUSE	SOLUTION
6. Needle breaks	<ol style="list-style-type: none"> 1. Sewing too close to the bag contents. 2. Looper setting is off. 3. Needle is askew in the sewing lever. 4. Poor synchronization with the system. 5. Operator pulling or holding the bag. 6. Needle guard worn or misaligned. 7. Presser foot is misaligned. 	<ol style="list-style-type: none"> 1. Put the machine a little higher. 2. Reset looper distances. 3. Check needle adjustment. 4. Examine synchronization. 5. Let go of the bag. 6. Replace or reset needle guard. 7. Reset the presser foot.
7. Bag gets stuck in the machine.	<ol style="list-style-type: none"> 1. Sewing head starts too late. 2. Synchronization with system is not correct. 3. Drive pulley of the sewing head incorrectly or not tensioned. 4. Bag too full. 5. Feed dog worn. 6. Throat plate worn or damaged. 7. Faulty feed into the machine. 8. Pressure on the presser foot base too high or too low. 	<ol style="list-style-type: none"> 1. Check. 2. Synchronize again. 3. Replace or tension. 4. Reduce contents. 5. Replace feed dog. 6. Replace throat plate. 7. Check system before feed into sewing head. 8. Adjust.
8. Bag tears	<ol style="list-style-type: none"> 1. Throat plate damaged. 2. Too much pressure on presser foot. 3. Damaged presser foot. 4. Stitches too close. 	<ol style="list-style-type: none"> 1. Replace throat plate. 2. Reduce pressure. 3. Replace presser foot. 4. Reset and check stitch length.
9. Sack tears on sewing line	<ol style="list-style-type: none"> 1. Too much thread tension. 2. Bag too thin. 3. Stitch too small. 	<ol style="list-style-type: none"> 1. Reduce tension. 2. Change bag type. 3. Increase size of stitch.
10. Skipped stitches	<ol style="list-style-type: none"> 1. Thread tension badly adjusted. 2. Thread pull off badly adjusted. 3. Poor quality thread. 	<ol style="list-style-type: none"> 1. Adjust thread tension. 2. Adjust again. 3. Use higher quality thread. (Fischbein lubricated thread)

**FISCHBEIN® MODELS 200 & 201 EMPRESS™ SERIES SEWING HEAD
OPERATOR'S MANUAL**

FAULT	CAUSE	SOLUTION
11. Chain is poorly cut	<ol style="list-style-type: none"> 1. Knives worn. 2. Pressure springs worn. 3. Too much material around the knife. 	<ol style="list-style-type: none"> 1. Replace Knives. See manual. 2. Replace the springs. 3. Blast with compressed air.
12. Wobbly sewing line	<ol style="list-style-type: none"> 1. Faulty feed. 2. Poor synchronization. 	<ol style="list-style-type: none"> 1. Operator or feed. 2. Check synchronization.
13. Noise and excessive vibration	<ol style="list-style-type: none"> 1. Internal components loose or worn. 2. Sewing head loose. 3. Pulley loose. 	<ol style="list-style-type: none"> 1. Fischbein technician. 2. Check and tighten screws. 3. Tension.
14. Sewing head will not turn	Internal parts broken.	Call Fischbein technician
15. Low oil pressure	<ol style="list-style-type: none"> 1. Not enough oil. 2. Faulty pump. 3. Faulty pressure gauge. 4. Drive pump broken. 5. Filter blocked. 	<ol style="list-style-type: none"> 1. Top up oil. 2. Change pump. 3. Change gauge. 4. Fischbein technician. 5. Replace filter.
16. Oil level too low or no oil	<ol style="list-style-type: none"> 1. Drain plug loose. 2. Oil leak looper seal. 3. Oil leak feed dog seal. 4. Bottom plate of sewing head is loose. 5. Bottom plate seal broken. 6. Oil gauge broken. 7. Sewing lever and presser foot lever seal broken. 	<ol style="list-style-type: none"> 1. Tighten plug. 2. Replace seal. 3. Replace seal. 4. Tighten. 5. Replace seal. 6. Replace oil gauge. 7. Replace seal.

**FISCHBEIN® MODELS 200 & 201 EMPRESS™ SERIES SEWING HEAD
OPERATOR'S MANUAL**

FAULT	CAUSE	SOLUTION
17. Tape scuffing (model 201 only)	<ol style="list-style-type: none"> 1. Tape reel drag too tight. 2. Tape width too wide for folder. 3. Alignment. 4. Dull feed dog. 5. Synchronization. 6. Too much drag. 7. Bent or damaged folder. 8. Feed dog and presser foot not properly adjusted. 9. Rough or sticky presser foot. 	<ol style="list-style-type: none"> 1. Loosen tape reel drag. 2. Check and change tape if necessary. 3. Check alignment between folder and sewing head and between tape reel and folder. 4. Check and replace if needed. 5. Check synchronization of sewing head, power infeed and conveyor. 6. Apply paraffin. 7. Replace or repair folder. 8. Adjust. 9. Clean or replace.
18. Tape binding (model 201 only)	Tape not correctly on tape reel holder.	Adjust tape reel collar and check folder.
19. Uneven taping on bag (model 201 only)	<ol style="list-style-type: none"> 1. Tape loaded incorrectly in the folder. 2. Tape too narrow for folder. 3. Folder guides out of adjustment. 4. Tape reel and /or folder misalign with head. 5. Folder blades out of adjustment. 	<ol style="list-style-type: none"> 1. Adjust. 2. Check and replace if needed. 3. Adjust. 4. Adjust alignment. 5. Adjust.
20. Tape wrinkling (model 201 only)	<ol style="list-style-type: none"> 1. Folder and sewing head out of alignment. 2. Rough or sticky build-up on presser foot. 3. Tape fence guide too far from presser foot. 	<ol style="list-style-type: none"> 1. Adjust. 2. Clean or replace presser foot. 3. Adjust.

**FISCHBEIN® MODELS 200 & 201 EMPRESS™ SERIES SEWING HEAD
OPERATOR'S MANUAL**

7. SPARE PARTS LIST

PARTS DESCRIPTION	PART NUMBER	QUANTITY
Gasket, Top Cover	10092	1
Lubricating Oil (1 quart)	31080	3 quarts
Screw, soc. flat #10 - 32 x ½ BO	SF103212	6
Oil Filter	15054	2
Gasket, Bottom Cover	10093	2
Blade, moveable knife	31112	1
Blade, fixed knife	31113	1
Knife, Bed - Wide (201 only)	10446	4
Knife, Moving - Wide (201 only)	10443	4
Guide, Rotary Knife Bag	31134	1
Gasket, Manifold Cover	10095	1
Plate, Throat (std) Wide and Medium (201 only)	31125	1
Plate, Throat (std) Narrow Tape (201 only)	31126	1
Gauge, Oil Pressure (60 lbs.)	15053	1
Seal, Lever Arms	31014	1
Needles, Square (package of 10)	C100-S	4
Chuck, Needle	10031	1
Screw, Needle Clamp	10011	2
Screw, soc cap #6 - 32 x ¾ BO G8	SC63234	2
Plug, Drilled Clamp (Presser Foot)	10213	1
Plug, Tapped Clamp (Presser Foot)	10214	1
Plug, Tapped Clamp (Needle Lever)	10212	1
Plug, Drilled Clamp (Needle Lever)	10211	1
Pad, Spring - Presser Foot	10190	1
Seal, Feed Dog	10077	2
Screw, Pan HD #5 - 40 x 9/16 SS	P540916	2
O-Ring, Feed Slide Rod	10075	2
Assembly, Looper & Knife Shaft Seal	15104	2
Gasket, Looper & Knife Shaft	15105	2
Feed Dog (200 only) Standard	10078	1
Feed Dog Wide Tape (201 only) Standard MV	10486	2
Feed Dog Narrow Tape (201 only) 1 ¼ Standard	10496	2
Feed Dog Medium Pull Tape (201 only)	10565	2
Looper, Two Thread	10060	4
Looper, Single Thread	10208	4
Screw, soc flat #8 - 32 x ½ BO	SF83212	4
Screw, soc flat #10 - 32 x 3/8 BO	SF103238	4
Presser Foot, Curved (200 only)	10185	1
Presser Foot (201 only) 2"-2.5" Wide Tape	10484	1
1 7/8" Medium Tape	10562	1
1 ¼" - 1 ½" Narrow Tape	10494	1
Narrow "Pull Tape" (Tear Tape)	10553	1
Wide "Pull Tape"	10558	1

8. DRAWINGS AND PARTS LISTS

SECTION	DESCRIPTION	PAGE #
8.1	MODEL 200 HOUSING	48-49
8.1.1	MODEL 201 HOUSING	50-51
8.2	MODEL 200 NEEDLE & PRESSER FOOT ASSEMBLIES	52-53
8.2.1	MODEL 201 NEEDLE & PRESSER FOOT ASSEMBLIES	54-55
8.3	MODEL 200 LEVER – HOUSING	56-57
8.3.1	MODEL 201 LEVER – HOUSING	58-59
8.4	MODEL 200 FEED ASSEMBLY	60-61
8.4.1	MODEL 201 FEED ASSEMBLY	62-63
8.5	MAINSHAFT ASSEMBLY	64-65
8.6	LOOPER ASSEMBLY	66
8.7	OIL – PUMP ASSEMBLY	67
8.8	TAPE CLIPPER	68-69
8.9	ROTARY AIR KNIFE (110VAC)	70-72
8.10	ROTARY AIR KNIFE (24VDC)	74-76

8.1

MODEL 200 HOUSING

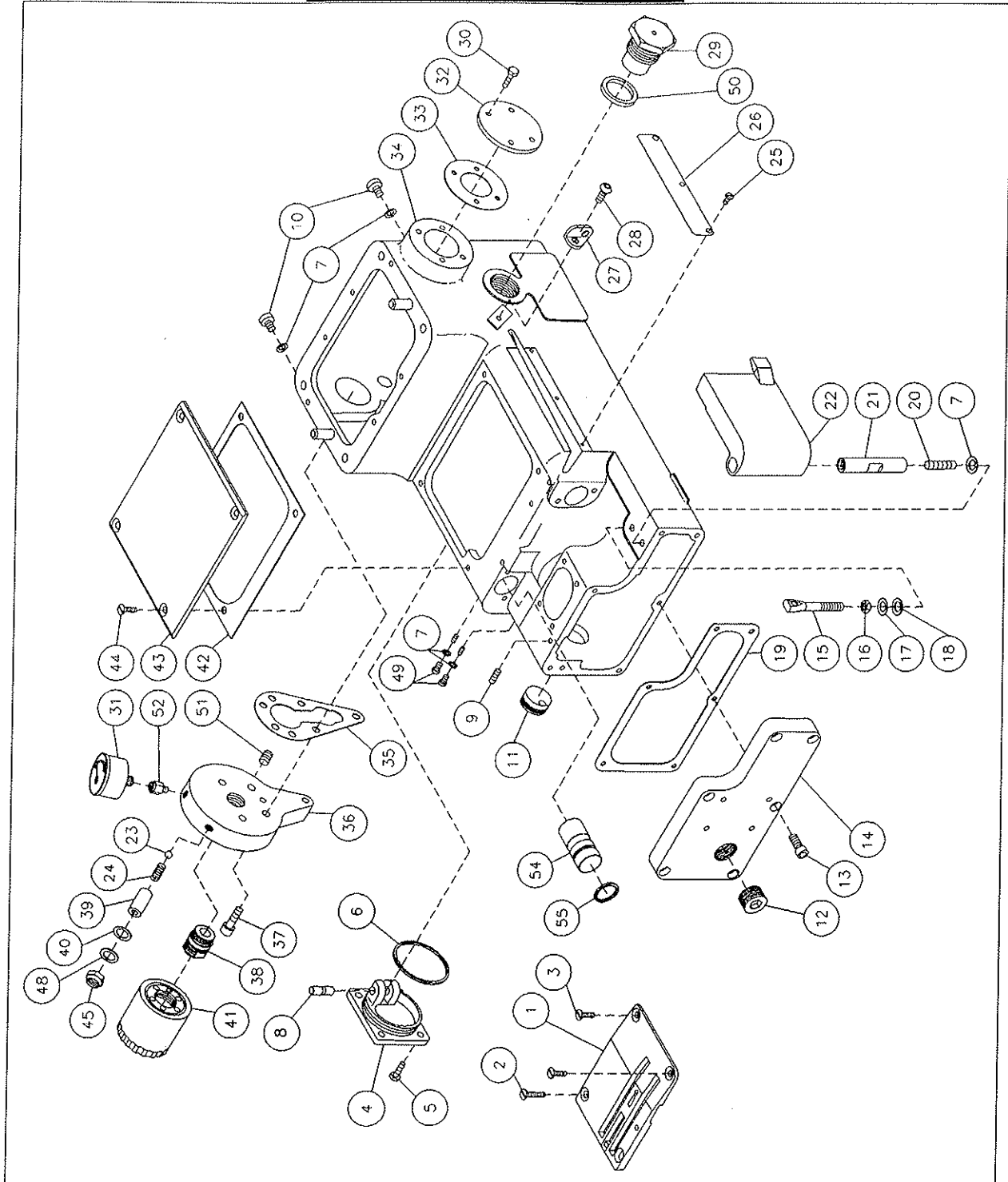

ITEM	Quantity	Item Code	Description:
1	1	31116	Throat plate
2	1	F103258	Screw, Flat HD 10-32 x 5/8
3	2	F103238	Screw, Flat HD 10-32 x 3/8
4	1	10085	Bracket, Pivot Knife
5	4	H103212	Screw, Hex 10-32 x 1/2
6	1	10084	O-ring

**FISCHBEIN® MODELS 200 & 201 EMPRESS™ SERIES SEWING HEAD
OPERATOR'S MANUAL**

ITEM	Quantity	Item Code	Description:
7	5	WN10	Washer, Nylon
8	1	10083	Shaft, Bell Crank - Knife
9	1	SS103214	Screw, Soc. Set 10-32 x ¼
10	2	B103214	Screw, Binding HD 10-32 x ¼
11	1	10112	Window, oil level
12	1	10111	Plug, drain – magnetic
13	6	SC103258	Screw, Soc. Cap 10-32 x 5/8
14	1	15072	Cover, bottom
15	1	10170	Pull off looper thread
16	1	NH1420	Nut, Hex 1/4-20
17	1	WF14	Washer, Flat ¼
18	1	10052	Washer, Nylon
19	1	10093	Gasket, cover – bottom
20	1	SS10321	Screw, Soc. Set 10-32 x 1
21	1	10016	Post, long – throat plate
22	1	10005	Door , looper
23	1	15069	Ball , chrome (part of Item 36 (15056) assy)
24	1	15078	Spring, pressure (part of Item 36 (15056) assy)
25	3	B632316	Screw, Binding HD 6-32 x 3/16
26	1	10098	Cover, groove – thread
27	1	10164	Eyelet, thread – short
28	1	SB103212	Screw, Soc. BTTN 10-32 x ½
29	1	10116	Assembly, plug – breather
30	4	H103212	Screw, Hex HD 10-32 x ½
31	1	15053	Gauge, oil pressure 60 PSI
32	1	15079	Plate, cover – side
33	1	10094	Gasket, mainshaft seal
34	1	31070	Housing, main
35	1	10095	Gasket, cover – manifold
36	1	15056	Manifold, filter-oil Assy (includes items 23,24,39,40,45,48)
37	5	SC103234	Screw, Soc. Cap 10-32 x 3/4
38	1	15062	Nipple , filter oil
39	1	15064	Plug, adjusting–manifold (part of Item 36 (15056) assy)
40	1	15074	Seal, Pressure Control Manifold (part of Item 36 (15056) assy)
41	1	15054	Cartridge, oil – filter
42	1	10092	Gasket, cover –top
43	1	10014	Plate, cover – top
44	4	F103238	Screw, Flat HD 10-32 x 3/8
45	1	11268	Nut, Lock (part of Item 36 (15056) assy)
46			
47			
48	1	A3934	Washer, Thrust (part of Item 36 (15056) assy)
49	2	B103238	Screw, Btn. 10-32 x 3/8
50	1	10338	O-ring 7/8 ID
51	1	10125	Plug 1/8 NPT
52	1	16034	Fitting, Adapter, 45 Deg
53			
54	1	10442	Plug
55	1	10441	O-ring, 5/8 ID

8.1.1

MODEL 201 HOUSING

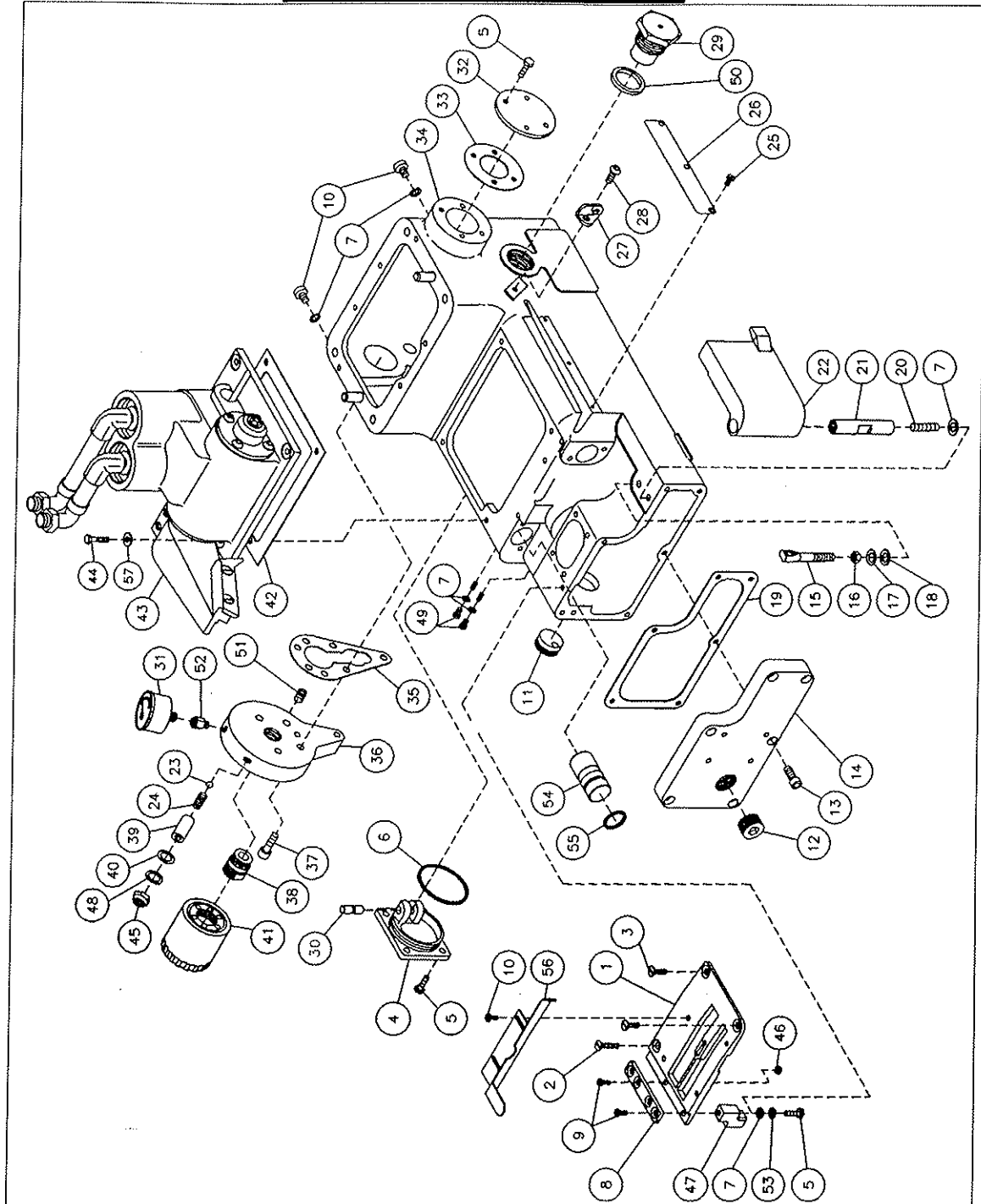

ITEM	Quantity	Item Code	Description:
1	1	31125	Throat plate, Tape (STD) Hi-Sp
2	1	F103258	Screw, Flat HD 10-32 x 5/8
3	2	F103238	Screw, Flat HD 10-32 x 3/8
4	1	10085	Bracket, Pivot Knife
5	5	H103212	Screw, Hex 10-32 x 1/2
6	1	10084	O-ring
7	6	WN10	Washer, Nylon
8	1	10446	Knife, Blade-Bed (wide)

**FISCHBEIN® MODELS 200 & 201 EMPRESS™ SERIES SEWING HEAD
OPERATOR'S MANUAL**

ITEM	Quantity	Item Code	Description:
9	2	F83212	Screw, Flat 8-32 x ½
10	4	B103214	Screw, Binding HD 10-32 x ¼
11	1	10112	Window, oil level
12	1	10111	Plug, drain – magnetic
13	6	SC103258	Screw, Soc. Cap 10-32 x 5/8
14	1	15072	Cover, bottom
15	1	10170	Pull off looper thread
16	1	NH1420	Nut, Hex 1/4-20
17	1	WF14	Washer, Flat ¼
18	1	10052	Washer, Nylon
19	1	10093	Gasket, cover – bottom
20	1	SS10321	Screw, Soc. Set 10-32 x 1
21	1	10016	Post, long – throat plate
22	1	10005	Door , looper
23	1	15069	Ball , chrome (part of Item 36 (15056) assy)
24	1	15078	Spring, pressure (part of Item 36 (15056) assy)
25	3	B632316	Screw, Binding HD 6-32 x 3/16
26	1	10098	Cover, groove – thread
27	1	10164	Eyelet, thread – short
28	1	SB103212	Screw, Soc. BTTN 10-32 x ½
29	1	10116	Assy, plug – breather
30	1	10083	Shaft, Bell Crank - Knife
31	1	15053	Gauge, oil pressure 60 PSI
32	1	15079	Plate, cover – side
33	1	10094	Gasket, mainshaft seal
34	1	31070	Housing, main
35	1	10095	Gasket, cover – manifold
36	1	15056	Manifold, filter- oil Assy (includes items 23,24,39,40,45,48)
37	5	SC103234	Screw, Soc. Cap 10-32 x 3/4
38	1	15062	Nipple , filter oil
39	1	15064	Plug, adjusting – manifold (part of Item 36 (15056) assy)
40	1	15074	Seal, Pressure Contrl-Manifold (part of Item 36 (15056) assy)
41	1	15054	Cartridge, oil – filter
42	1	10092	Gasket, cover –top
43	1	31035	Assy, Clipper
44	4	H103258	Screw, Hex HD 10-32 x 5/8
45	1	11268	Nut, Lock (part of Item 36 (15056) assy)
46	1	NH832	Nut, Hex 8-32
47	1	10434	Post-Offset
48	1	A3934	Washer, Thrust (part of Item 36 (15056) assy)
49	2	B103238	Screw, BTTN. 10-32 x 3/8
50	1	10338	O-ring 7/8 ID
51	1	10125	Plug 1/8 NPT
52	1	16034	Fitting, Adapter, 45 Deg.
53	1	WF10	Washer, Flat #10
54	1	10442	Plug
55	1	10441	O-ring, 5/8 ID
56	1	10449	Fence, Throat
57	4	10438	Washer, Compression

8.2 MODEL 200 NEEDLE & PRESSER FOOT ASSEMBLIES

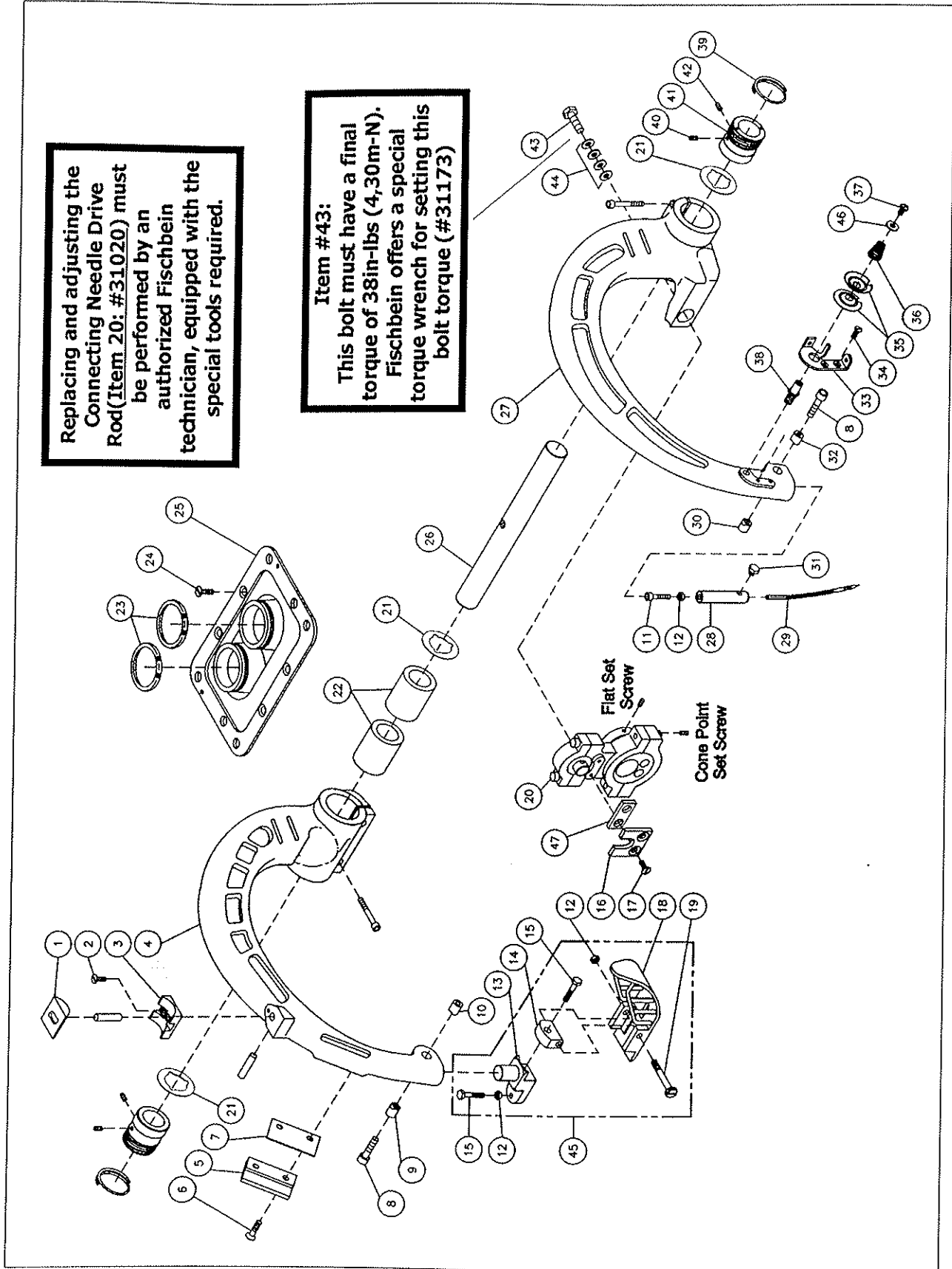

**FISCHBEIN® MODELS 200 & 201 EMPRESS™ SERIES SEWING HEAD
OPERATOR'S MANUAL**

ITEM	Quantity	Item Code	Description:
1	1	10190	Pad, spring presser foot
2	1	F63214	Screw, Flat 6-32 x 1/4
3	1	10189	Cradle, pad presser foot
4	1	10004	Lever, presser foot
	2	SC14201	Screw, Soc. Cap 1/4-20 x 1
	2	PS14112	Pin, Spring
5	1	10163	Clamp, bearing sheet
6	2	SF103258	Screw, Soc. Flat 10-32 x 5/8
7	1	10162	Sheet, bearing presser foot
8	2	SC63234	Screw, Soc. Cap 6-32 x 3/4
9	1	10213	Plug, clamp drilled (presser foot)
10	1	10214	Plug, clamp tapped (presser foot)
11	1	SC103234	Screw, Soc. Cap 10-32 x 3/4
12	3	11309	Nut Hex – Special CZ
13	1	10155	Shank, presser foot
14	1	10156	Block, hinger presser foot
15	2	H103234	Screw, Hex 10-32 x 3/4
16	1	10048	Retainer, rod connecting
17	2	SF103238	Screw, Soc. Flat 10-32 x 3/8
18	1	10185	Presser foot
19	1	10182	Bolt, hinging presser foot
20	1	31056	Rod, connecting needle drive
	1	15109	Screw, Set Cone 1/4-20 x 3/8
	1	SS142014	Screw, Soc. Set 1/4-20 x 1/4
21	3	31042	Washer, Thrust (special)
22	2	10029	Bushing, lever presser foot
23	2	10128	Spring, garter lever seal
24	4	F103238	Screw, Flat 10-32 x 3/8
25	1	31014	Seal, levers
26	1	10026	Shaft, lever
27	1	31024	Lever, needle
	2	SC1420114	Screw, Soc. Cap 1/4-20 x 1 1/4
28	1	10031	Chuck needle
29	1	C100-S	Needle
30	1	10212	Plug, clamp tapped
31	1	10011	Screw, clamp needle
32	1	10211	Plug, clam drilled
33	1	10166	Guide, thread (needle lever)
34	2	F54038	Screw, Flat 5-40 x 3/8
35	2	10119	Disc, tension (needle lever)
36	1	10009	Spring, tension (needle lever)
37	1	B103214	Screw, Binding HD 10-32 x 1/4
38	1	10113	Stud, tension (needle lever)
39	2	10023	Insert, thread – lever shaft bushing
40	2	SS1032516	Screw, Soc. Set 10-32 x 5/16
41	2	10025	Bushing, shaft levers
42	2	SS1032316	Screw, Soc. Set 10-32 x 3/16
43	1	H142812	Bolt, Hex 1/4-28 x 1/2
44	4	15076	Washer, Spring 1/4
45		10157	Assembly, presser foot
46	1	WF8	Washer, Flat #8
47	1	31048	Spacer, Rod - Connecting

8.2.1 MODEL 201 NEEDLE & PRESSER FOOT ASSEMBLIES

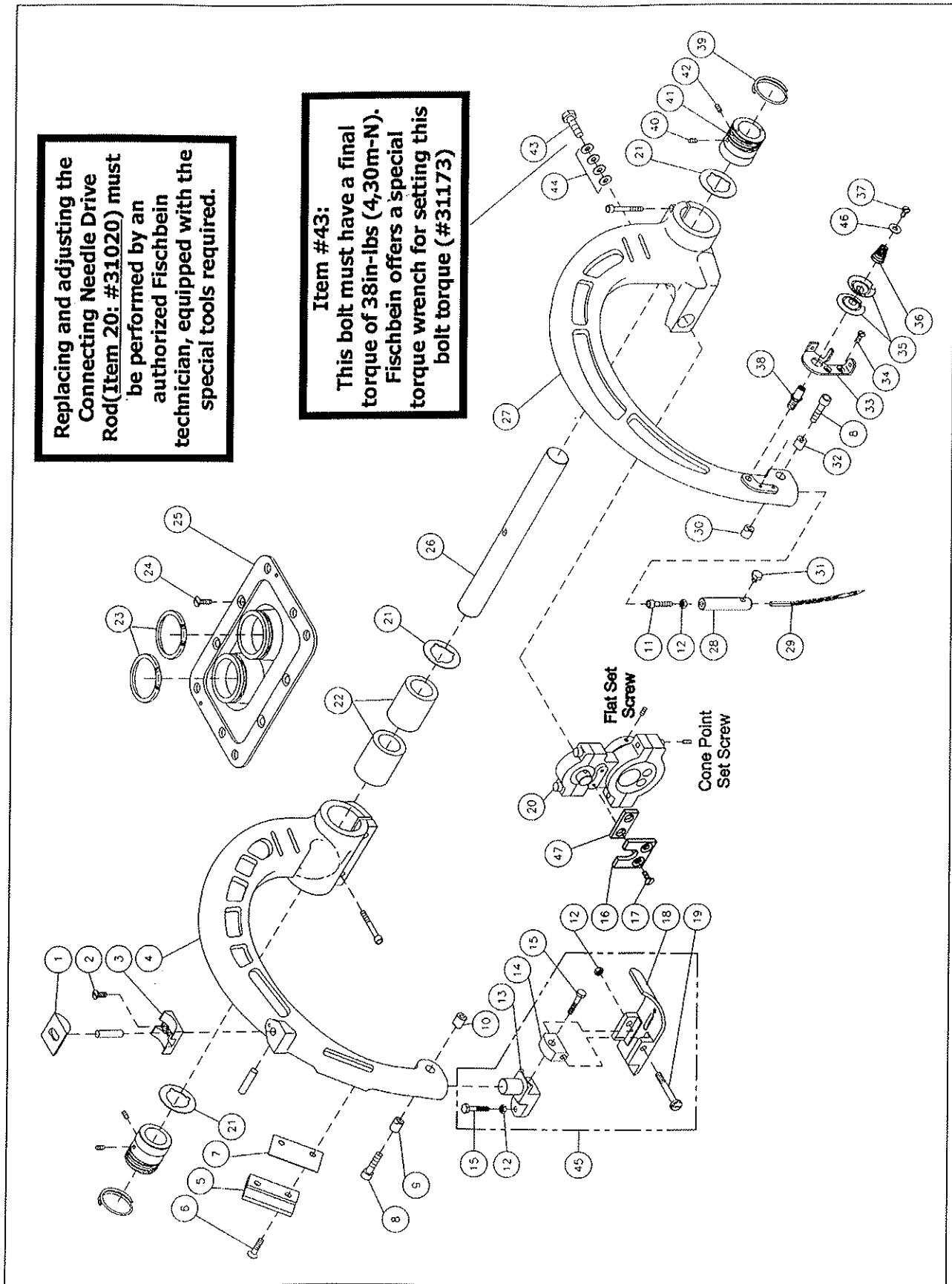

**FISCHBEIN® MODELS 200 & 201 EMPRESS™ SERIES SEWING HEAD
OPERATOR'S MANUAL**

ITEM	Quantity	Item Code	Description:
1	1	10190	Pad, spring presser foot
2	1	F63214	Screw, Flat 6-32 x 1/4
3	1	10189	Cradle, pad presser foot
4	1	10004	Lever, presser foot
	2	SC14201	Screw, Soc. Cap 1/4-20 x 1
	2	PS14112	Pin, Spring
5	1	10163	Clamp, bearing sheet
6	2	SF103258	Screw, Soc. Flat 10-32 x 5/8
7	1	10162	Sheet, bearing presser foot
8	2	SC63234	Screw, Soc. Cap 6-32 x 3/4
9	1	10213	Plug, clamp drilled (presser foot)
10	1	10214	Plug, clamp tapped (presser foot)
11	1	SC103234	Screw, Soc. Cap 10-32 x 3/4
12	3	11309	Nut, Hex – Special CZ
13	1	10155	Shank, presser foot
14	1	10156	Block, hinger presser foot
15	2	H103234	Screw, Hex 10-32 x 3/4
16	1	10048	Retainer, rod connecting
17	2	SF103238	Screw, Soc. Flat 10-32 x 3/8
18	1	10484	Presser foot, Tape (wide)
19	1	10182	Bolt, hinging presser foot
20	1	31056	Rod, connecting needle drive
	1	15109	Screw, Set Cone 1/4-20 x 3/8
	1	SS142014	Screw, Soc. Set 1/4-20 x 1/4
21	3	31042	Washer, Thrust (special)
22	2	10029	Bushing, lever presser foot
23	2	10128	Spring, garter lever seal
24	4	F103238	Screw, Flat 10-32 x 3/8
25	1	31014	Seal, levers
26	1	10026	Shaft, lever
27	1	31024	Lever, needle
	2	SC1420114	Screw, Soc. Cap 1/4-20 x 1 1/4
28	1	10031	Chuck needle
29	1	C100-S	Needle
30	1	10212	Plug, clamp tapped
31	1	10011	Screw, clamp needle
32	1	10211	Plug, clam drilled
33	1	10166	Guide, thread (needle lever)
34	2	F54038	Screw, Flat 5-40 x 3/8
35	2	10119	Disc, tension (needle lever)
36	1	10009	Spring, tension (needle lever)
37	1	B103214	Screw, Binding HD 10-32 x 1/4
38	1	10113	Stud, tension (needle lever)
39	2	10023	Insert, thread – lever shaft bushing
40	2	SS1032516	Screw, Soc. Set 10-32 x 5/16
41	2	10025	Bushing, shaft levers
42	2	SS1032316	Screw, Soc. Set 10-32 x 3/16
43	1	H142812	Bolt, Hex 1/4-28 x 1/2
44	4	15076	Washer, Spring 1/4
45		10481	Assy, Presser Foot, Tape (wide)
46	1	WF8	Washer, Flat #8
47	1	31048	Spacer, Rod - Connecting

8.3

MODEL 200 LEVER - HOUSING

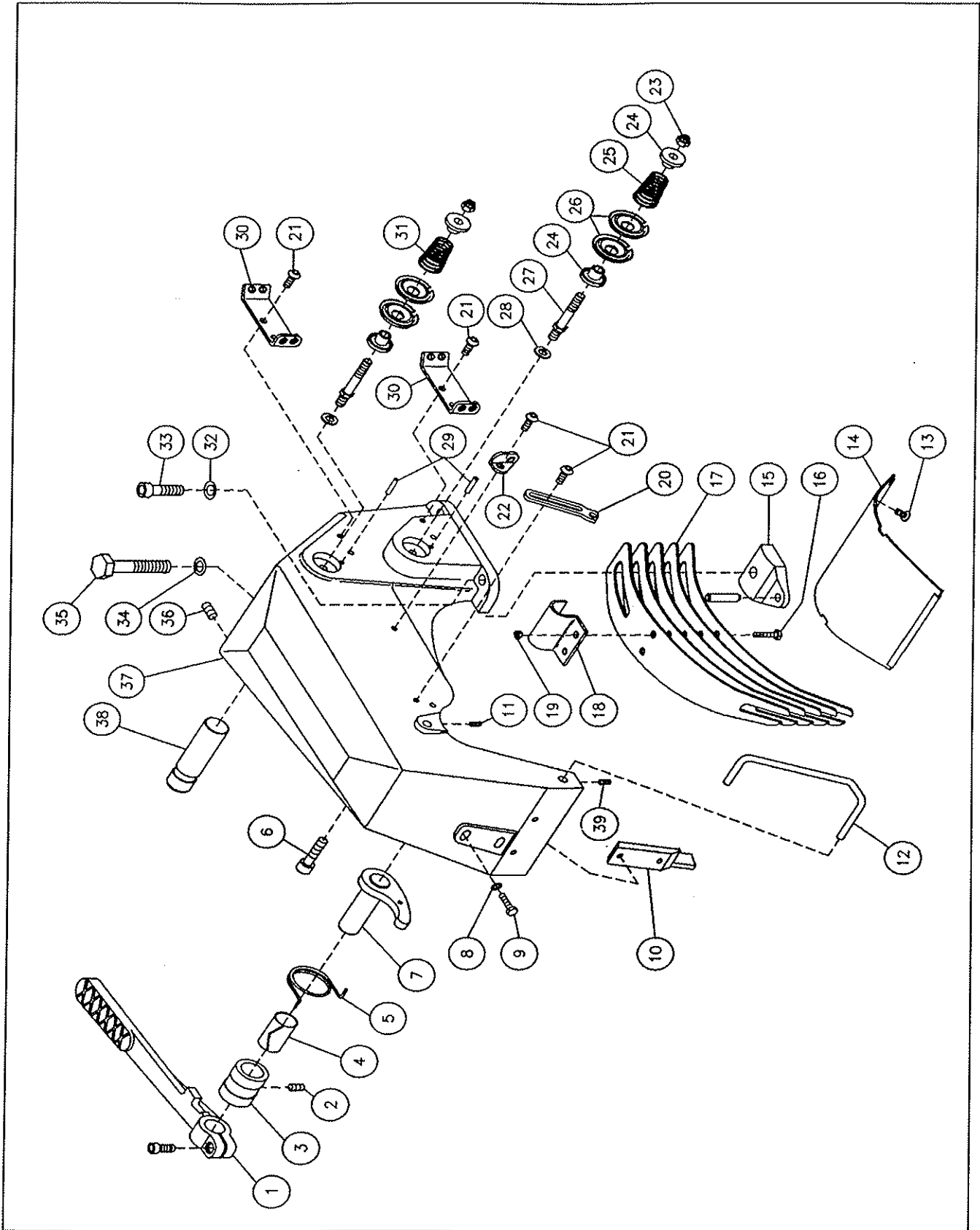

**FISCHBEIN® MODELS 200 & 201 EMPRESS™ SERIES SEWING HEAD
OPERATOR'S MANUAL**

ITEM	Quantity	Item Code	Description:
1	1	31034	Lever, lifter presser foot
	1	SC142034	Screw, Soc. Cap 1/4-20 x 3/4
2	1	SS142014	Screw, Soc. Set 1/4-20 x 1/4
3	1	10139	Bushing, lifter presser foot
4	1	10186	Liner, bushing lifter presser foot
5	1	10187	Spring, lifter lever
6	1	SC5161858	Screw, Soc. Cap. 5/16-18 x 5/8
7	1	10142	Cam, lifter presser foot
8	2	WS10	Washer, Spring 10
9	2	H103278	Screw, Hex HD 10-32 x 7/8
10	1	10161	Guide, lever presser foot
11	1	SS1032516	Screw, Soc. Set 10-32 x 5/16
12	1	10188	Guard, tension needle
13	2	B103238	Screw, Binding HD 10-32 x 3/8
14	1	31031	Cover, guard lever
15	1	10146	Plate, presser foot
	1	PS141	Pin, Spring
16	2	H103234	Screw, Hex HD 10-32 x 3/4
17	5	10145	Spring, presser foot
18	1	10144	Clamp, spring presser foot
19	2	1-178	Nut, Lock
20	1	10171	Pull off, needle thread
21	7	SB103212	Screw, Soc. BTTN 10-32 x 1/2
22	1	10164	Eyelet, thread short
23	2	NH1428L	Nut, Hex 1/4-28 locking
24	4	10114	Sleeve, tension
25	1	10008	Spring, tension looper thread
26	4	10120	Disc, tension large
27	2	10115	Stud, tension
28	2	11120	Washer, lock
29	2	PS18114	Pin, Spring retaining tension disc
30	2	10165	Eyelet, thread long (Guide)
31	1	10007	Spring, tension needle thread
32	4	10234	Washer, Spring
33	4	SC516181	Screw, Soc. Cap 5/16-18 x 1
34	1	WF38	Washer, Flat 3/8
35	1	H3824134	Screw, Adj. 3/8-24 x 1 3/4
36	1	SS142038	Screw, Soc. Set 1/4-20 x 3/8
37	1	31075	Housing, levers
38	1	10143	Shaft, spring presser foot
39	1	SS1032316	Screw, Soc. Set 10-32 x 3/16
40			

8.3.1

MODEL 201 LEVER - HOUSING

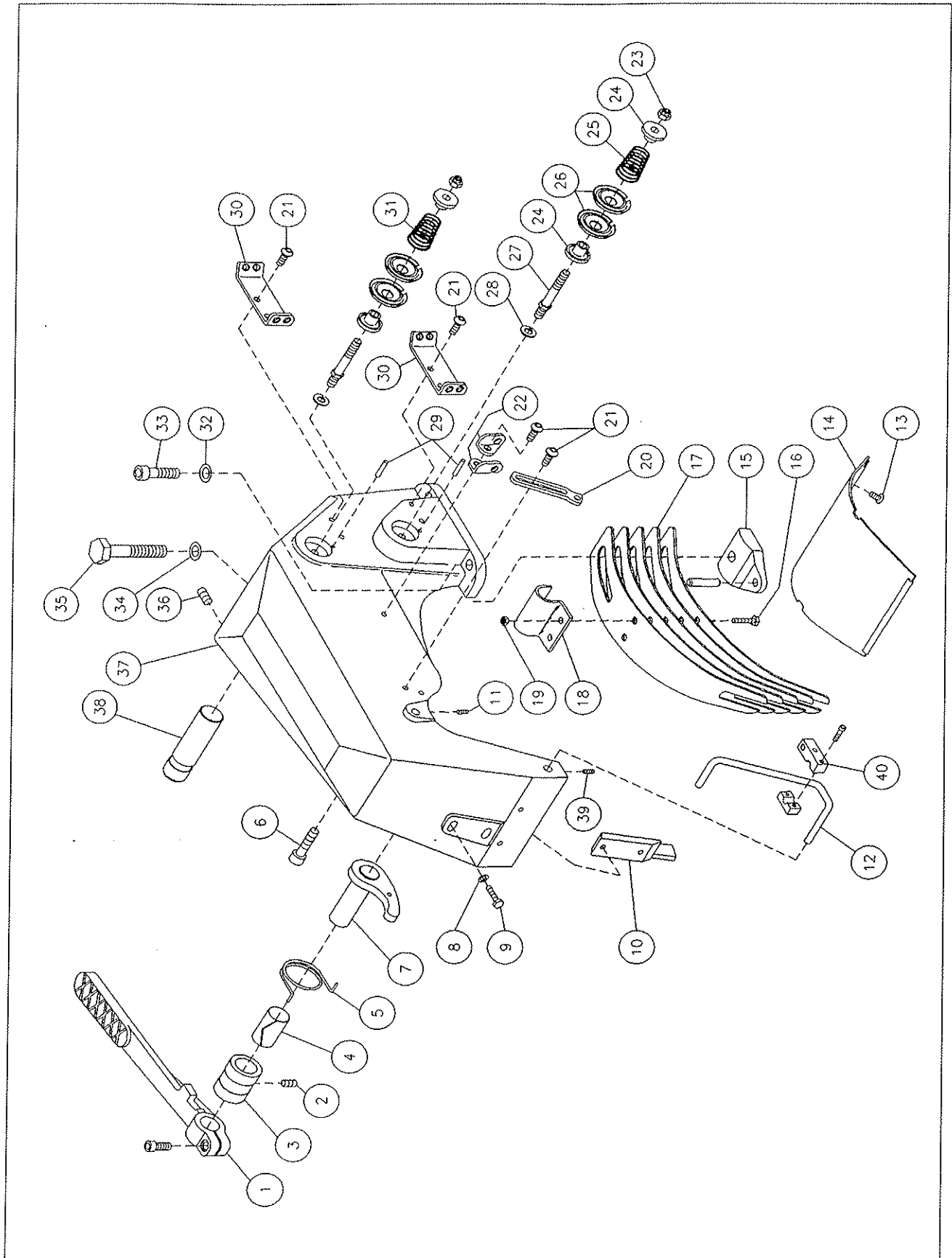

**FISCHBEIN® MODELS 200 & 201 EMPRESS™ SERIES SEWING HEAD
OPERATOR'S MANUAL**

ITEM	Quantity	Item Code	Description:
1	1	31034	Lever, lifter presser foot
	1	SC142034	Screw, Soc. Cap 1/4-20 x 3/4
2	1	SS142014	Screw, Soc. Set 1/4-20 x 1/4
3	1	10139	Bushing, lifter presser foot
4	1	10186	Liner, bushing lifter presser foot
5	1	10187	Spring, lifter lever
6	1	SC5161858	Screw, Soc. Cap. 5/16-18 x 5/8
7	1	10142	Cam, lifter presser foot
8	2	WS10	Washer, Spring 10
9	2	H103278	Screw, Hex HD 10-32 x 7/8
10	1	10161	Guide, lever presser foot
11	1	SS1032516	Screw, Soc. Set 10-32 x 5/16
12	1	10188	Guard, tension needle
13	2	B103238	Screw, Binding HD 10-32 x 3/8
14	1	31031	Cover, guard lever
15	1	10146	Plate, presser foot
	1	PS141	Pin, Spring
16	2	H103234	Screw, Hex HD 10-32 x 3/4
17	5	10145	Spring, presser foot
18	1	10144	Clamp, spring presser foot
19	2	1-178	Nut, Lock
20	1	10171	Pull off, needle thread
21	7	SB103212	Screw, Soc. BTTN 10-32 x 1/2
22	2	10164	Eyelet, thread short
23	2	NH1428L	Nut, Hex 1/4-28 locking
24	4	10114	Sleeve, tension
25	1	10008	Spring, tension looper thread
26	4	10120	Disc, tension large
27	2	10115	Stud, tension
28	2	11120	Washer, lock
29	2	PS18114	Pin, Spring retaining tension disc
30	2	10165	Eyelet, thread long (Guide)
31	1	10721	Spring, tension-light needle thread
32	4	10234	Washer, Spring
33	4	SC516181	Screw, Soc. Cap 5/16-18 x 1
34	1	WF38	Washer, Flat 3/8
35	1	H3824134	Screw, Adj. 3/8-24 x 1 1/4
36	1	SS142038	Screw, Soc. Set 1/4-20 x 3/8
37	1	31075	Housing, levers
38	1	10143	Shaft, spring presser foot
39	1	SS1032316	Screw, Soc. Set 10-32 x 3/16
40	1	10216	Eyelet, Rip Cord

8.4

MODEL 200 FEED ASSEMBLY

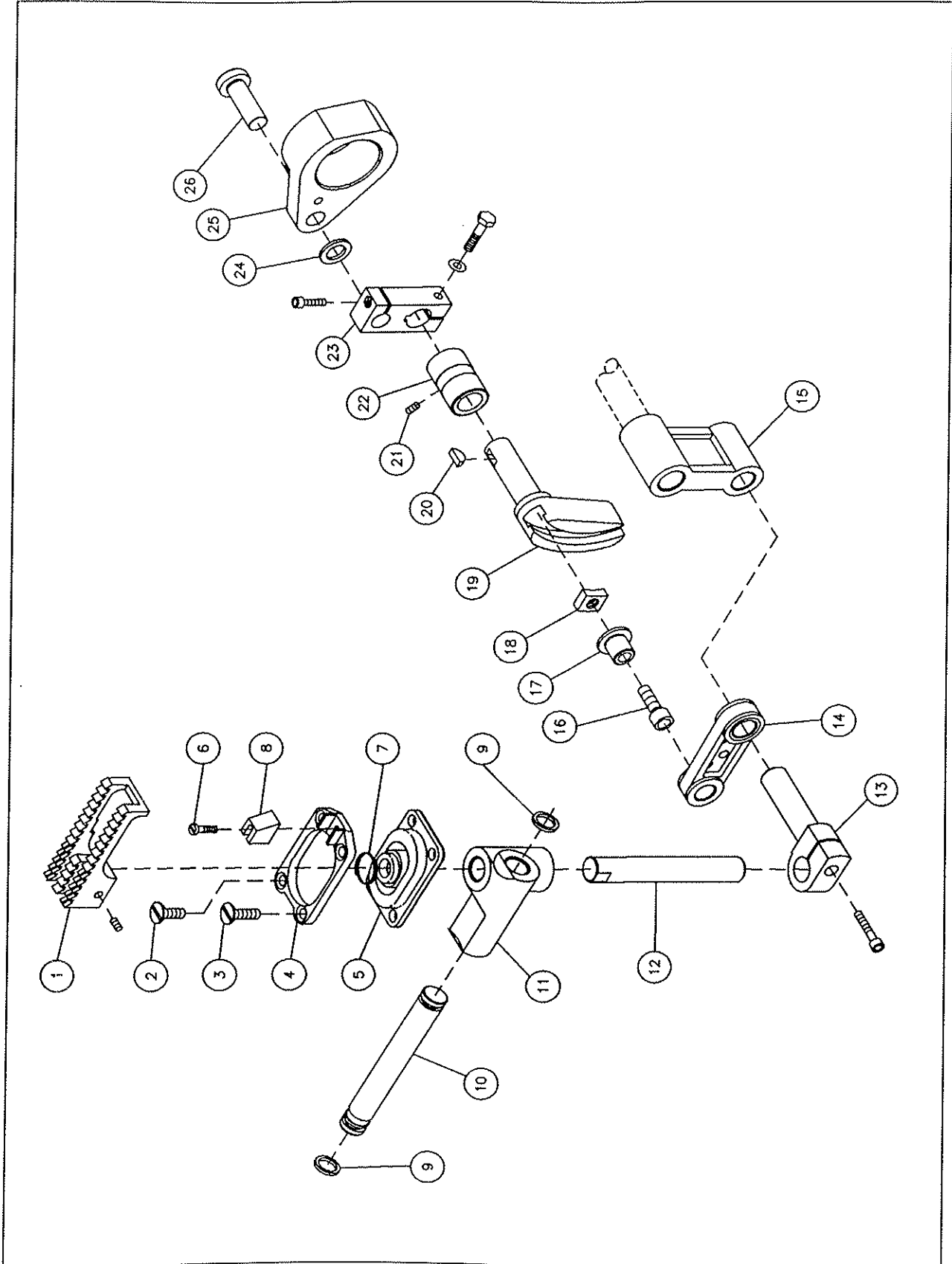

**FISCHBEIN® MODELS 200 & 201 EMPRESS™ SERIES SEWING HEAD
OPERATOR'S MANUAL**

ITEM	Quantity	Item Code	Description:
1	1	10078	Dog feed
	1	SS1032516	Screw, Soc. Set 10-32 x 5/16
2	1	F103238	Screw, Flat HD 10-32 x 3/8
3	3	F103212	Screw, Flat HD 10-32 x 1/2
4	1	10177	Holder, guard needle
5	1	10077	Seal, dog feed
6	1	P540916	Screw, Pan HD 5-40 x 9/16
7	1	10124	Ring, Garter-Seal (Feed Dog)
8	1	10174	Guard, needle
9	2	10075	O-ring
10	1	31012	Rod, slide feed
11	1	10073	Slide feed
12	1	31011	Rod, carrier feed dog
13	1	31008	Clamp, rod feed dog carrier
	1	SC142078	Screw, Soc. Cap 1/4-20 x 7/8
14	1	31010	Link, stroke feed
15	1	31009	Link, lift feed
16	1	SC142878	Screw, Soc. Cap 1/4-28 x 7/8
17	1	10068	Pivot, adjusting feed stroke
18	1	10067	Nut, pivot feed stroke
19	1	31007	Lever, slotted feed rocker
20	1	T3192	Key
21	1	SS1032516	Screw, Soc. Set 10-32 x 5/16
22	1	10109	Bushing, shaft feed rocker
23	1	31005	Lever, pin feed rocker
	1	SC54012	Screw, Soc. Cap 5-40 x 1/2
	1	H103234	Screw, Hex 10-32 x 3/4
	1	WF10	Washer, Flat # 10
24	1	10215	Washer, Thrust
25	1	31072	Rod, connecting prim. Feed stroke
26	1	31006	Pin, rod feed stroke connect.

8.4.1

MODEL 201 FEED ASSEMBLY

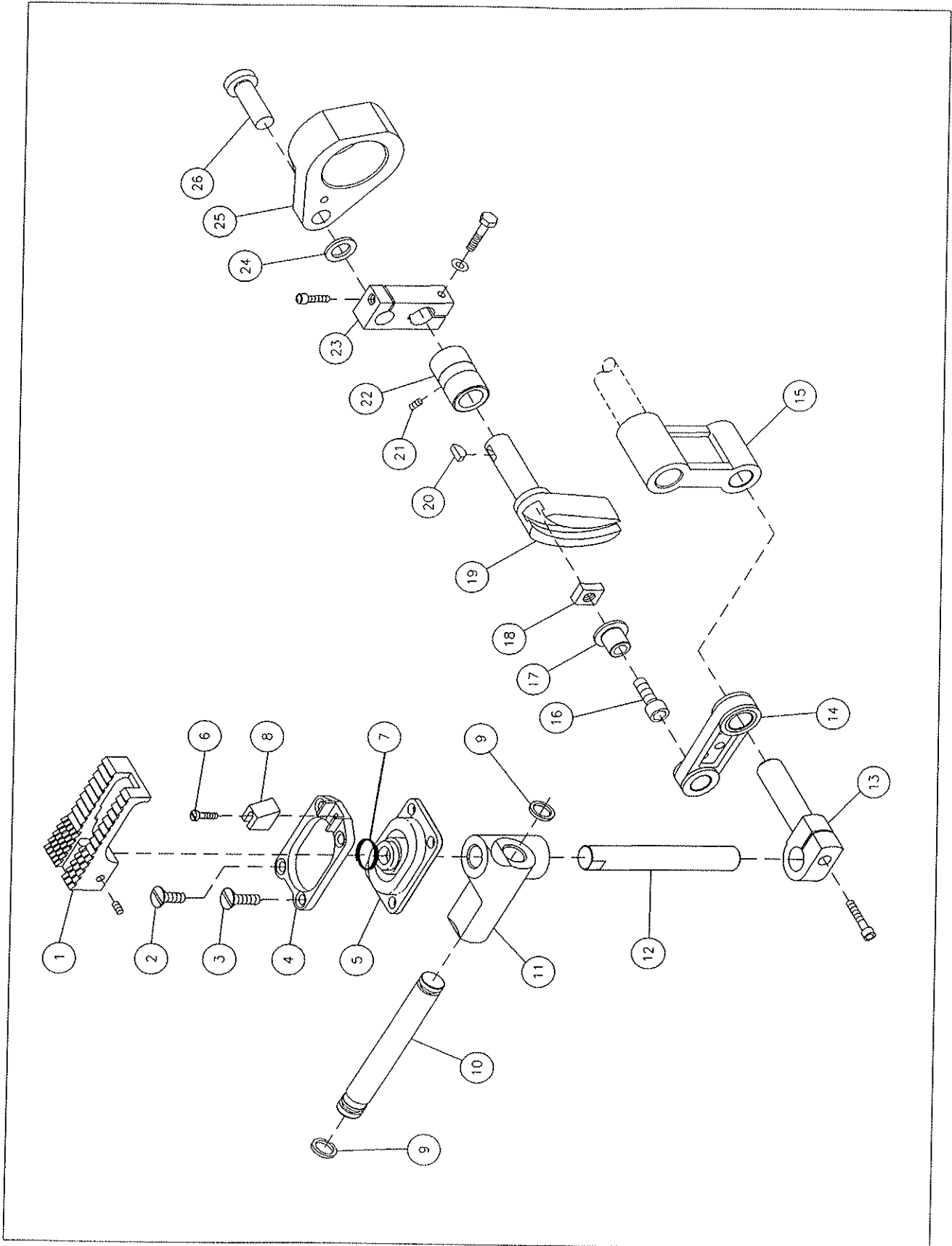

**FISCHBEIN® MODELS 200 & 201 EMPRESS™ SERIES SEWING HEAD
OPERATOR'S MANUAL**

ITEM	Quantity	Item Code	Description:
1	1	10486	Dog, feed, Tape (STD)
	1	SS1032516	Screw, Soc. Set 10-32 x 5/16
2	1	F103238	Screw, Flat HD 10-32 x 3/8
3	3	F103212	Screw, Flat HD 10-32 x 1/2
4	1	10177	Holder, guard needle
5	1	10077	Seal, dog feed
6	1	P540916	Screw, Pan HD 5-40 x 9/16
7	1	10124	Ring, Garter-Seal (Feed Dog)
8	1	10174	Guard, needle
9	2	10075	O-ring
10	1	31012	Rod, slide feed
11	1	10073	Slide feed
12	1	31011	Rod, carrier feed dog
13	1	31008	Clamp, rod feed dog carrier
	1	SC142078	Screw, Soc. Cap 1/4-20 x 7/8
14	1	31010	Link, stroke feed
15	1	31009	Link, lift feed
16	1	SC142878	Screw, Soc. Cap 1/4-28 x 7/8
17	1	10068	Pivot, adjusting feed stroke
18	1	10067	Nut, pivot feed stroke
19	1	31007	Lever, slotted feed rocker
20	1	T3192	Key
21	1	SS1032516	Screw, Soc. Set 10-32 x 5/16
22	1	10109	Bushing, shaft feed rocker
23	1	31005	Lever, pin feed rocker
	1	SC54012	Screw, Soc. Cap 5-40 x 1/2
	1	H103234	Screw, Hex 10-32 x 3/4
	1	WF10	Washer, Flat # 10
24	1	10215	Washer, Thrust
25	1	31072	Rod, connecting prim. Feed stroke
26	1	31006	Pin, rod feed stroke connect.

8.5

MAIN SHAFT

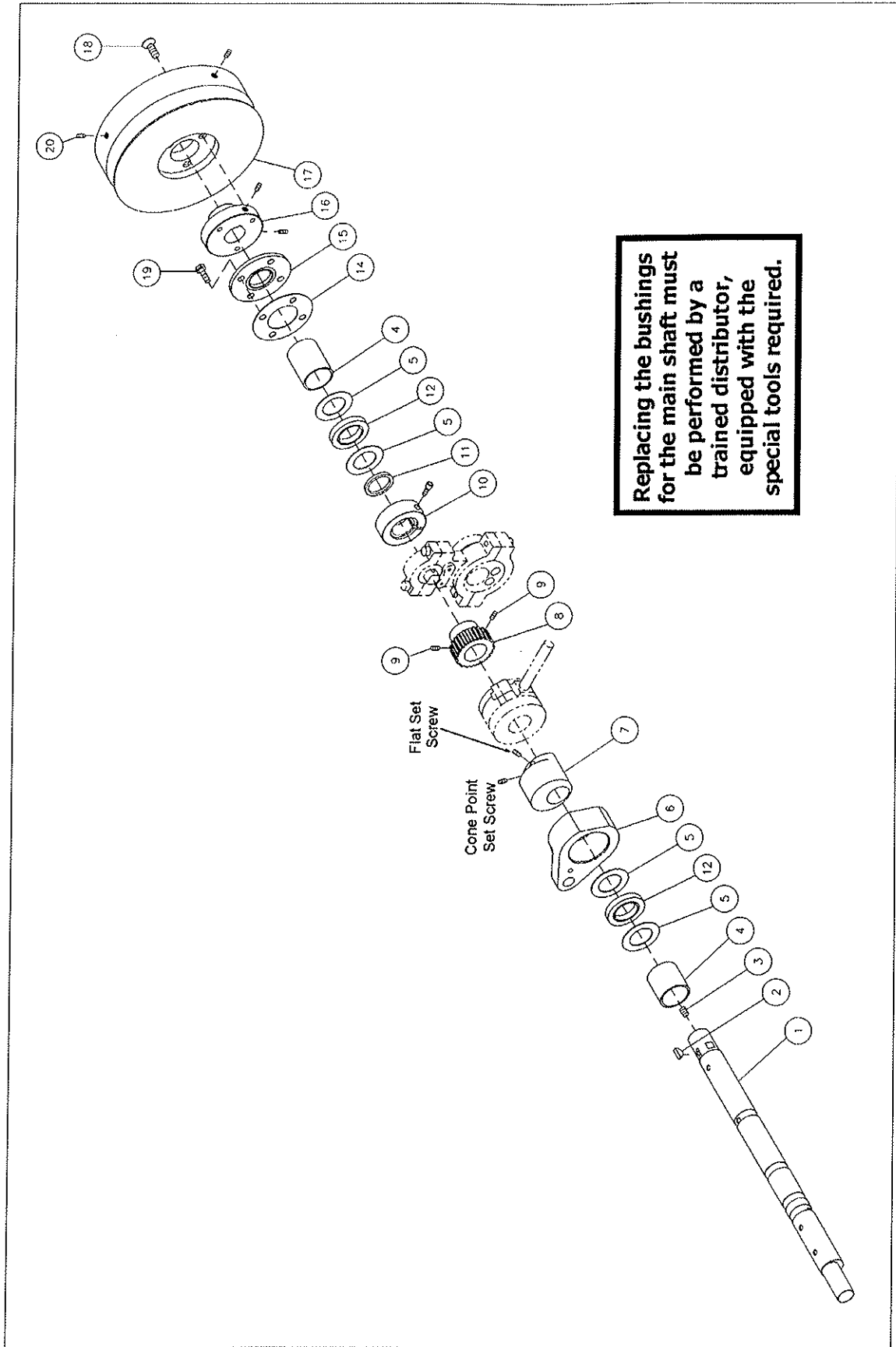

**FISCHBEIN® MODELS 200 & 201 EMPRESS™ SERIES SEWING HEAD
OPERATOR'S MANUAL**

ITEM	Quantity	Item Code	Description:
1	1	31050	Shaft, Main (Hi-Sp)
2	1	T3192	Key
3	1	10125	Plug, pipe main shaft (Hi-Sp)
4	2	31061	Bushing, main shaft needle end (Hi-Sp)
5	4	31064	Washer, Thrust (Hi-Sp)
6	1	31072	Rod, connecting prim. Feed stroke (Hi-Sp)
7	1	31051	Eccentric, stroke feed (Hi-Sp)
	1	15108	Screw, Set ¼-20 x 3/8
	1	15109	Screw, Set Cone Point ¼-20 x 3/8
8	1	31055	Gear, drive pump (Hi-Sp)
9	2	SS83218	Screw, Soc. Set 8-32 x 1/8
10	1	31066	Collar, lock main shaft (Hi-Sp)
	1		Screw, Soc. Cap HD ¼-28 x 5/8
11	1	31059	O-ring (Hi-Sp)
12	2	31065	Bearing, thrust (Hi-Sp)
14	1	10094	Gasket, main shaft seal
15	1	10035	Assembly, seal main shaft
16	1	10038	Hub, pulley
	2	15108	Screw, Set 1/4-20 x 3/8
17	1	10199	Pulley, adjustable
18	3	SF103258	Screw, Soc. Flat 10-32 x 5/8
19	4	SC103212	Screw, Soc. Cap 10-32 x ½
20	2	15108	Screw, Soc. Set ¼-20 x 3/8

8.6

LOOPER ASSEMBLY

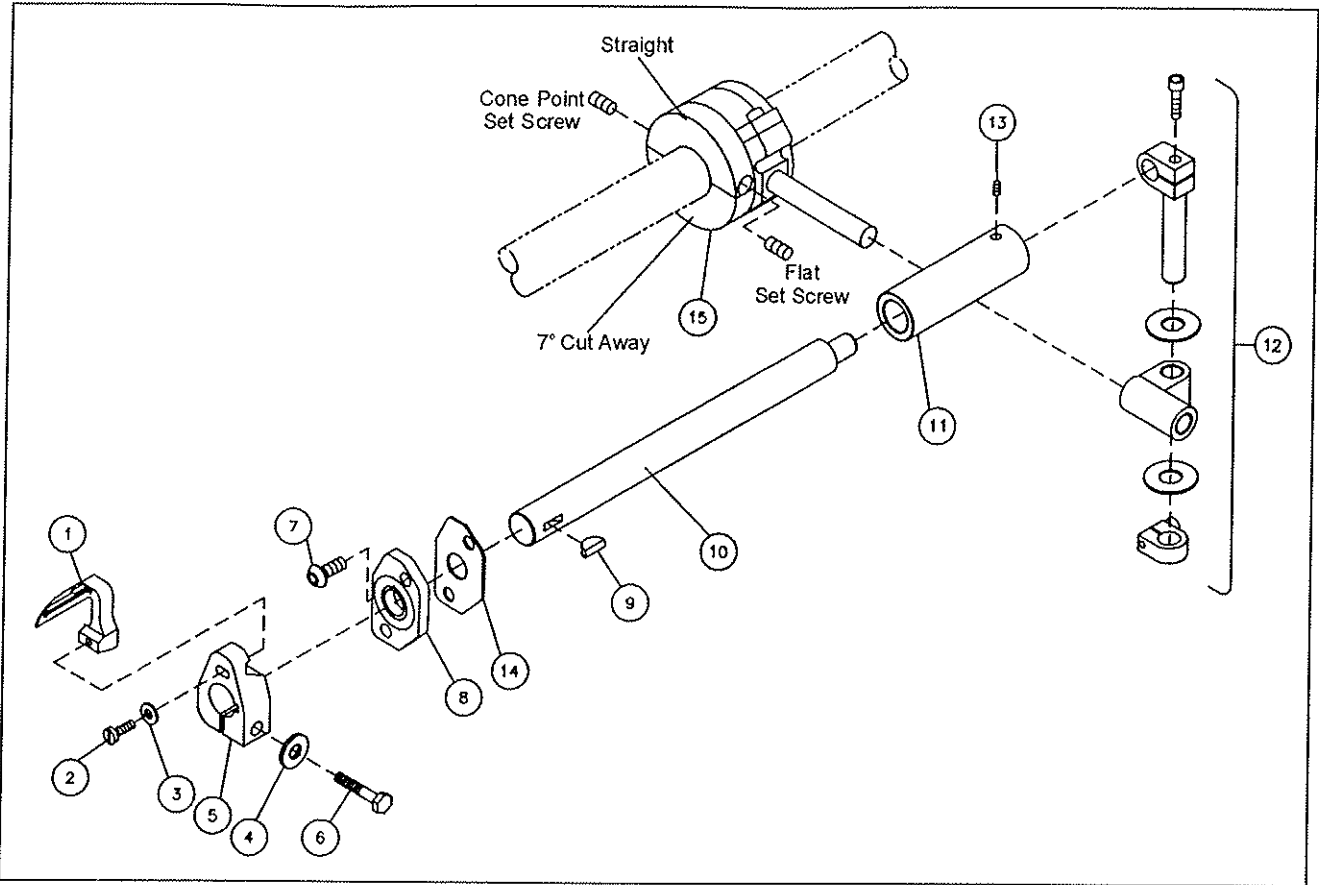

ITEM	Quantity	Item Code	Description:
1	1	10060	Looper
2	1	SC54012	SCREW, Soc. Cap #5-40 X 1/2 BO G5
3	1	WF5	Washer, Flat 5
4	1	WF10	Washer, Flat 10
5	1	10059	Holder, Looper
6	1	H103234	Screw, Hex 10-32 x 3/4
7	2	SB103212	Screw, Soc. BTTN 10-32 x 1/2
8	1	15104	Assembly, Seal, Knife Shaft
9	1	T3192	Key
10	1	31013	Shaft, Looper
11	1	10056	Bushing, Shaft Looper
12	1	10173	Assembly, Pivot Looper
	2	15066	Washer, Thrust
	1	15065	Clamp, Knuckle Assembly
	1	15039	Pin, Pivot Looper
	1	10153	Knuckle, Pivot Looper
	1	SC103258	Screw, Soc. Cap 10-32 x 5/8
13	1	SS103214CP	Screw, Soc. Set 10-32 x 1/4 cone point
14	1	15105	Gasket, Looper Shaft Seal
15	1	31052	Assembly Cam, Looper (Hi-Sp)
	1	SS103258CP	Screw, Soc. Set Cone Point 10-32 x 5/8
	1	SS103212	Screw, Soc. Set 10-32 x 1/2

8.7

OIL - PUMP ASSEMBLY

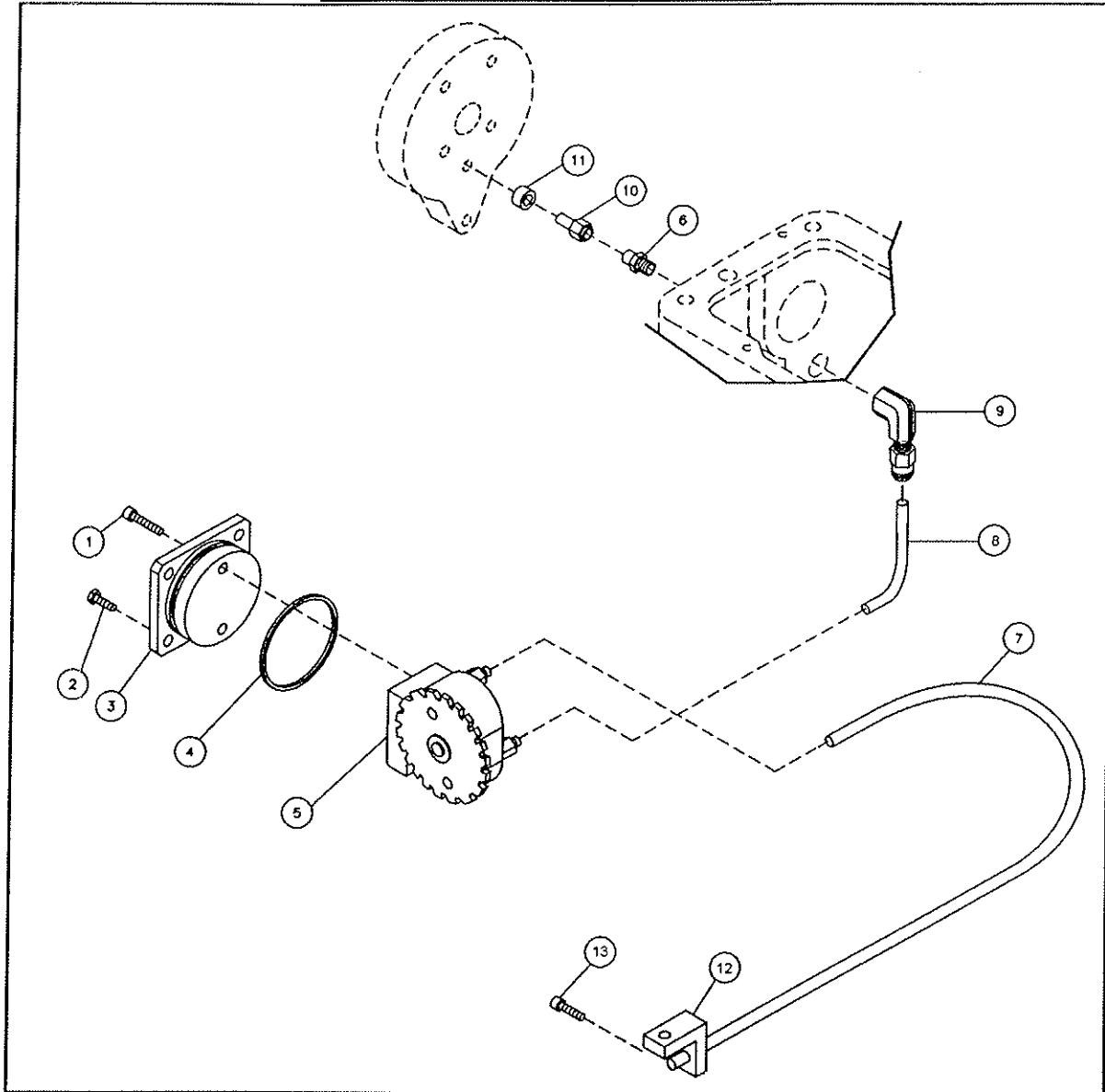

ITEM	Quantity	Item Code	Description:
1	2	SC103278	Screw, Soc. Cap 10-32 x 7/8
2	4	H103212	Screw, Hex HD 10-32 x 1/2
3	1	15015	Mount, pump
4	1	10084	O-ring
5	1	31096	Assembly, Gear Pump (Modified)
6	1	15059	Fitting, Male Conn 1/8 M X 1/4 T
7	18in (458mm)	67735	Tubing, Hydraulic 1/4 OD X .170 ID
8	3.5 in (89mm)	67735	Tubing, Hydraulic 1/4 OD X .170 ID
9	1	31045	Fitting, 1/8 FMNPT X 1/4 T (SP) (Modified)
10	1	15088	Tubing, copper
11	1	A1882	Bushing, neoprene
12	1	31043	Bracket, Oil Line (Plastic)
13	1	SC54012	Screw, Soc. Cap #5-40 X 1/2 BO G5

8.8

TAPE CLIPPER (31035)

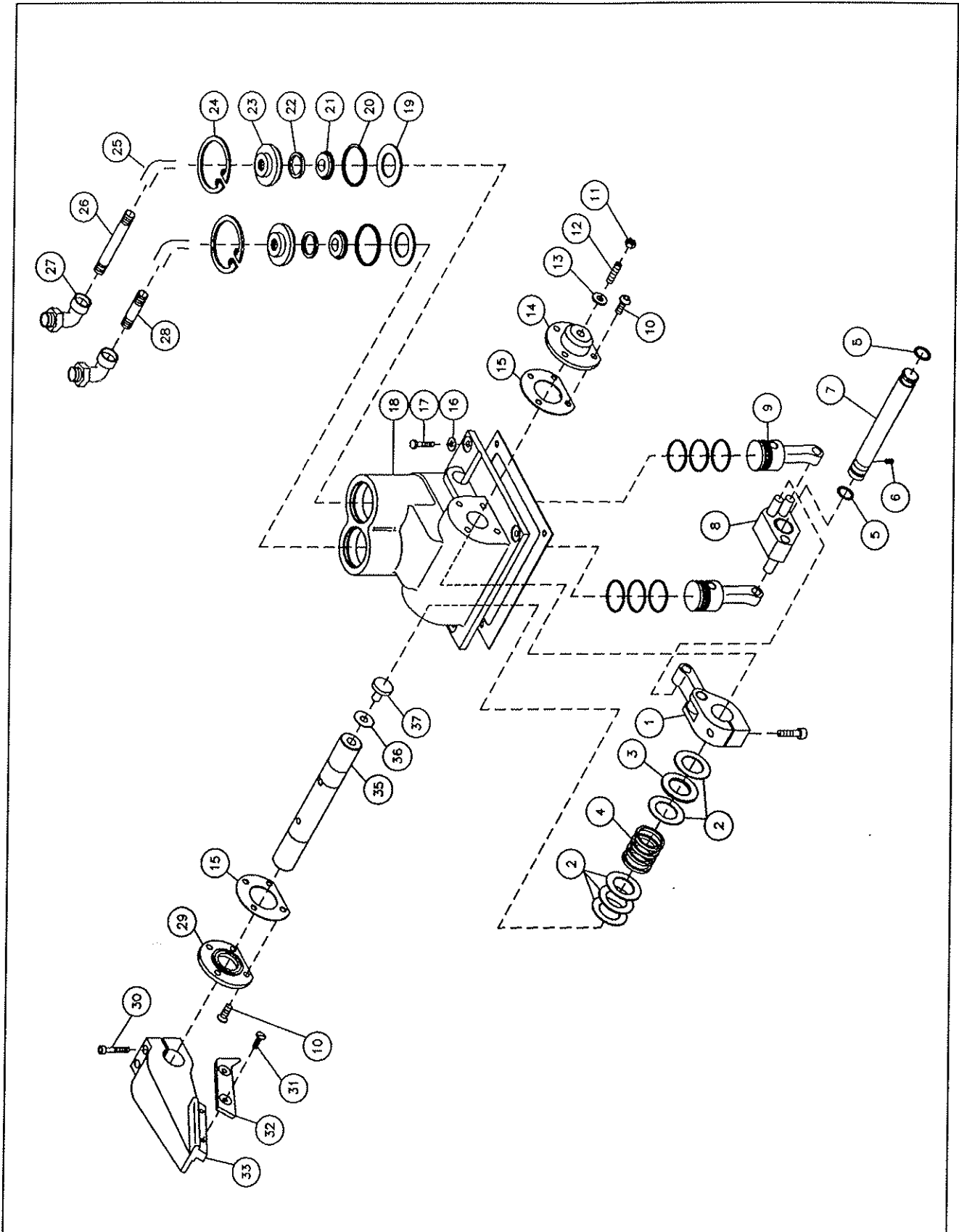

**FISCHBEIN® MODELS 200 & 201 EMPRESS™ SERIES SEWING HEAD
OPERATOR'S MANUAL**

ITEM	Quantity	Item Code	Description:
1	1	10447	Assembly, Lever Cutter
	1	SC14201	Screw, Soc. Cap 1/4-20 x 1 Locking
2	5	T3129	Washer, Thrust
3	1	P4024	Bearing, Thrust
4	1	10424	Spring, Compression
5	2	10420	O-ring-Crankshaft
6	1	SS1032316	Screw, Soc. Set 10-32 x 3/16
7	1	10419	Crankshaft
8	1	10404	Assembly, Crank
9	2	10458	Assembly, Piston-Tape Clipper
	4	10398	Ring, Backup
	2	10399	U-Cup
10	4	SB103214	Screw, BTTN 10-32 x 1/4
11	1	NH1428	Nut, Hex 1/4-28
12	1	10440	Screw, Adjusting
13	1	10052	Washer, Nylon
14	1	10430	Plate, Cover
15	2	10429	Gasket
REF	1	10092	Gasket, Cover-Top
16	4	10438	Washer, Compression
17	4	H103258	Screw, Hex 10-32 x 5/8
18	1	31036	Housing, Cutter
19	2	10406	Washer, Head Cylinder
20	2	10409	O-ring, Cylinder Head
21	2	10407	Plate, Bumper
22	2	10408	Ring, Bumper
23	2	10410	Head, Cylinder
24	2	10411	Ring, Snap
25	2	P4957	Fitting, Street Elbow
26	1	P4944	Fitting, Nipple Long
27	2	P4962	Fitting Elbow Female
28	1	P4943	Fitting, Nipple Short
29	1	10403	Assembly, Seal-Shaft
30	2	SC1420114	Screw, Soc. Cap 1/4-20 x 1 1/4
31	2	F103212	Screw, Flat 10-32 x 1/2
32	1	10443	Knife, Moving
33	1	10432	Lever, Knife
34			
35	1	10426	Shaft, Knife
36	1	10428	Washer, Thrust
37	1	10427	Shaft, Thrust

8.9

AIR KNIFE (31130) (110 VAC)

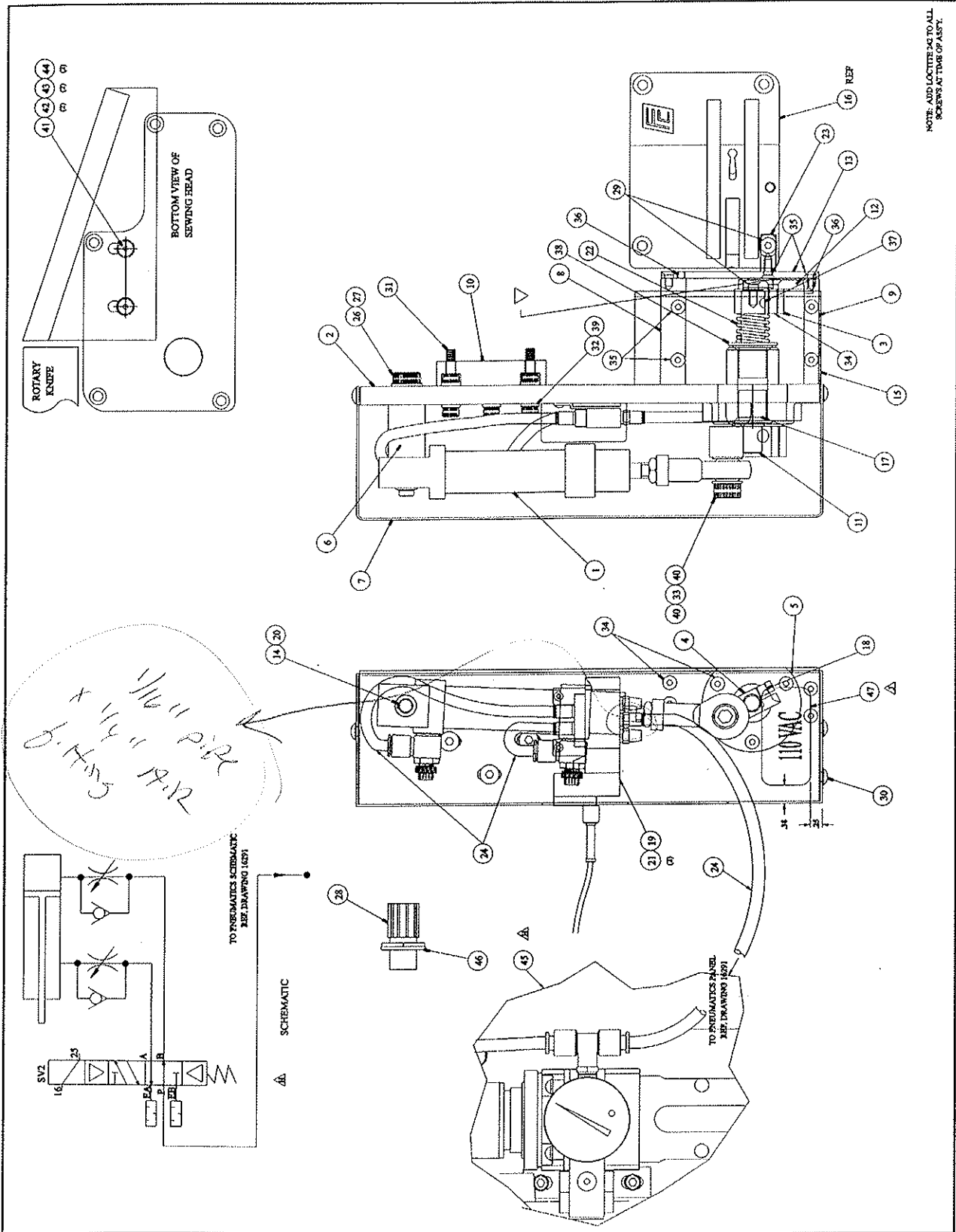

**FISCHBEIN® MODELS 200 & 201 EMPRESS™ SERIES SEWING HEAD
OPERATOR'S MANUAL**

ITEM	Quantity	Item Code	Description
1	1	31101	KIT, AIR CYLINDER ASSY
2	1	31131	PLATE, SUPPORT
3	1	31103	HUB, MOVABLE KNIFE MOUNTING
4	1	31104	LEVER, AIR CYLINDER DRIVE
5	1	31105	HUB, DRIVESHAFT SUPPORT
6	1	31106	PIN, AIR CYLINDER PIVOT
7	1	31132	COVER
8	1	31108	BRACKET, UPPER FIXED BLADE
9	1	31109	BRACKET, LOWER FIXED BLADE
10	1	31110	BLOCK, MOUNTING
11	1	31111	SHAFT, MOVABLE KNIFE
12	1	31112	BLADE, MOVABLE KNIFE
13	1	31113	BLADE, FIXED KNIFE
14	1	15066	WASHER, THRUST-.312 ID X .750
15	1	31115	COVER, SIDE
16	REF	31124	PLATE, THROAT (LONG STITCH) HI-SP
16	REF	31116	PLATE, THROAT (STD) HI-SP
16	REF	31037	PLATE, THROAT (STD) LO-SP
16	REF	31038	PLATE, THROAT (LONG STITCH) LO-SP
17	2	31117	BEARING, DU FLANGED
18	1	SFM510	SCREW, SOC FLAT M5 X 10mm
19	1	31128	KIT, SOLENIOD
20	1	31120	E-RING, CIRCLIP D8
21	2	PHM258	SCREW, PAN HD M2.5 X 8mm
22	1	31122	SPRING, COMPRESSION
23	1	31123	BLOCK, MOUNTING THROAT PLATE
24	6.0 FT	31129	TUBING, POLYURETHENE, GREEN, 6mm
25			
26	1	WFM10	WASHER, FLAT M10
27	1	SCM1022	SCREW, HEX M10 X 22mm
28	1	16035	CORDGRIP, 1/2NPT
29	2	SFM412	SCREW, SOC FLAT M4 X 12mm
30	3	SBM510	SCREW, SOC BUTTON M5 X 10mm
31	4	SC103278	SCREW, SOC CAP #10-32 UNF X 7/8
32	4	SCM618	SCREW, SOC CAP M6 X 18mm
33	1	SCM825	SCREW, SOC CAP M8 X 25mm
34	8	SFM416	SCREW, SOC FLAT M4 X 16mm
35	7	SFM48	SCREW, SOC FLAT M4 X 8mm
36	4	SSM46	SCREW, SOC SET M4 X 6mm
37	2	T3192	KEY, WOODDRUFF

**FISCHBEIN® MODELS 200 & 201 EMPRESS™ SERIES SEWING HEAD
OPERATOR'S MANUAL**

ITEM	Quantity	Item Code	Description
38	1	WFM12	WASHER, FLAT M12
39	4	WFM6	WASHER, FLAT M6
40	2	WFM8	WASHER, FLAT M8
41	1	31156	GUIDE, AIR KNIFE BAG
42	2	SC103238	SCREW, SOC CAP #10-32 UNF X 3/8
43	2	WF10	WASHER, FLAT #10
44	2	WL10	WASHER, LOCK #10
45	REF	16291	DWG, PNEU SCHEM STD NEEDLE COOLER
46	1	P4139	SEAL, MOISTURE (1/2")
47	1	31158	LABEL, VOLTAGE (110 V)

FISCHBEIN® MODELS 200 & 201 EMPRESS™ SERIES SEWING HEAD
OPERATOR'S MANUAL

(blank page)

8.10

AIR KNIFE (31165) (24 VDC)

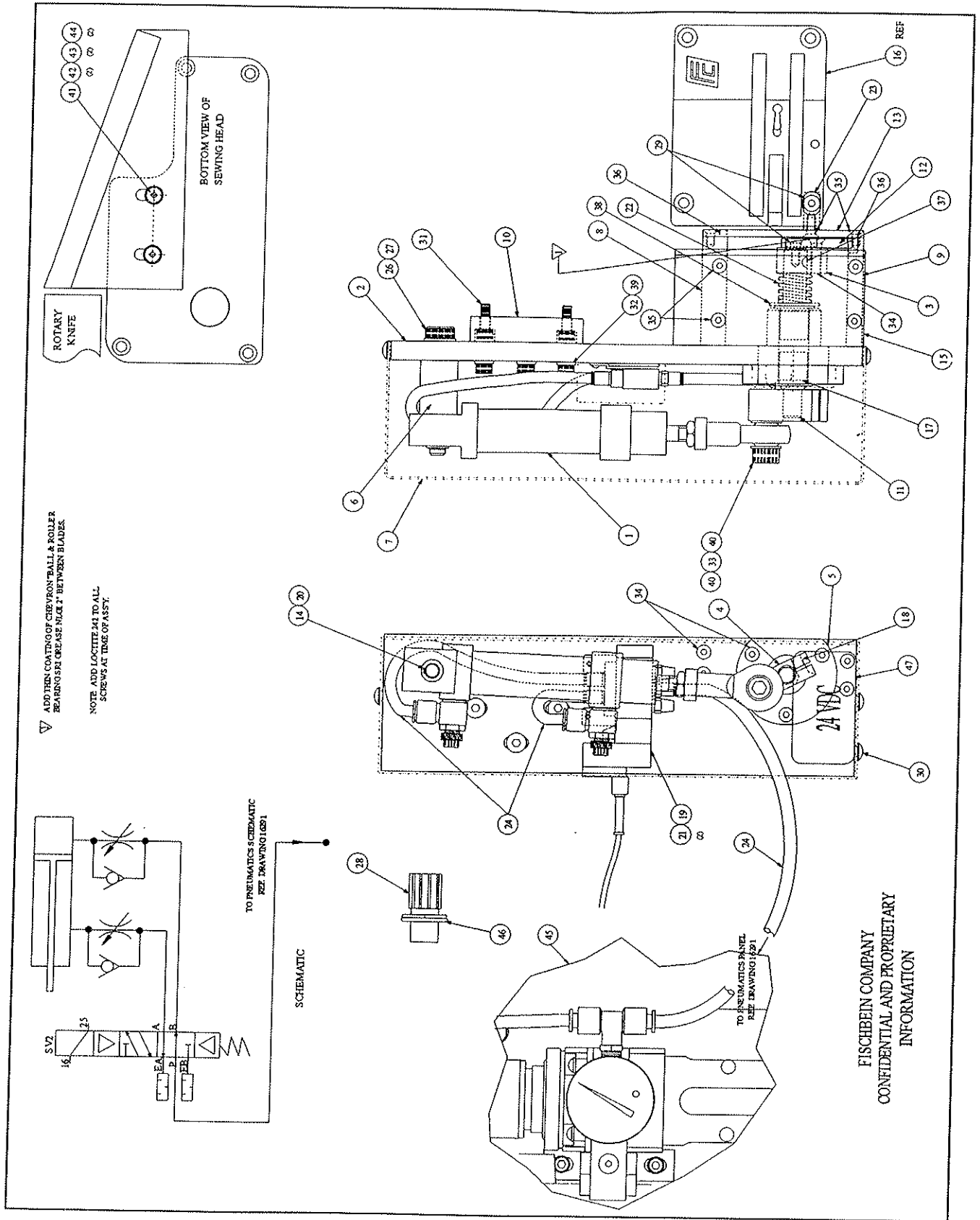

**FISCHBEIN® MODELS 200 & 201 EMPRESS™ SERIES SEWING HEAD
OPERATOR'S MANUAL**

Item	Quantity	Part No.	Description
1	1	31101	KIT, AIR CYLINDER ASSY
2	1	31131	PLATE, SUPPORT
3	1	31103	HUB, MOVABLE KNIFE MOUNTING
4	1	31104	LEVER, AIR CYLINDER DRIVE
5	1	31105	HUB, DRIVESHAFT SUPPORT
6	1	31106	PIN, AIR CYLINDER PIVOT
7	1	31132	COVER
8	1	31108	BRACKET, UPPER FIXED BLADE
9	1	31109	BRACKET, LOWER FIXED BLADE
10	1	31110	BLOCK, MOUNTING
11	1	31111	SHAFT, MOVABLE KNIFE
12	1	31112	BLADE, MOVABLE KNIFE
13	1	31113	BLADE, FIXED KNIFE
14	1	15066	WASHER, THRUST-.312 ID X .750
15	1	31115	COVER, SIDE
16	REF	31124	PLATE, THROAT (LONG STITCH) HI-SP
16	REF	31116	PLATE, THROAT (STD) HI-SP
16	REF	31037	PLATE, THROAT (STD) LO-SP
16	REF	31038	PLATE, THROAT (LONG STITCH) LO-SP
17	2	31117	BEARING, DU FLANGED
18	1	SFM510	SCREW, SOC FLAT M5 X 10mm
19	1	31162	KIT, SOLENIOD, 24VDC
20	1	31120	E-RING, CIRCLIP D8
21	2	PHM258	SCREW, PAN HD M2.5 X 8mm
22	1	31122	SPRING, COMPRESSION
23	1	31123	BLOCK, MOUNTING THROAT PLATE
24	6.0 ft (1.83m)	31129	TUBING, POLYURETHENE, GREEN, 6mm
25			
26	1	WFM10	WASHER, FLAT M10
27	1	SCM1022	SCREW, HEX M10 X 22mm
28	1	16035	CORDGRIP, 1/2NPT
29	2	SFM412	SCREW, SOC FLAT M4 X 12mm
30	3	SBM510	SCREW, SOC BUTTON M5 X 10mm
31	4	SC103278	SCREW, SOC CAP #10-32 UNF X 7/8
32	4	SCM618	SCREW, SOC CAP M6 X 18mm

**FISCHBEIN® MODELS 200 & 201 EMPRESS™ SERIES SEWING HEAD
OPERATOR'S MANUAL**

Item	Quantity	Part No.	Description
33	1	SCM825	SCREW, SOC CAP M8 X 25mm
34	8	SFM416	SCREW, SOC FLAT M4 X 16mm
35	7	SFM48	SCREW, SOC FLAT M4 X 8mm
36	4	SSM46	SCREW, SOC SET M4 X 6mm
37	2	T3192	KEY, WOODDRUFF
38	1	WFM12	WASHER, FLAT M12
39	4	WFM6	WASHER, FLAT M6
40	2	WFM8	WASHER, FLAT M8
41	1	31156	GUIDE, AIR KNIFE BAG
42	2	SC103238	SCREW, SOC CAP #10-32 UNF X 3/8
43	2	WF10	WASHER, FLAT #10
44	2	WL10	WASHER, LOCK #10
45	REF	16291	DWG, PNEU SCHEM STD NEEDLE COOLER
46	1	P4139	SEAL, MOISTURE (1/2")
47	1	31148	LABEL, VOLTAGE (24 VDC)

9. MACHINE SET UP PARTS LISTS

9.1 MODEL 200

<u>PRESSER FOOT</u>		<u>THROAT PLATE</u>	<u>FEED DOG</u>
Std. Curved (Replacement)	10185	31116	10078 (4 Ctr. Teeth)
Std. Curved Assembly	10157	31116	10078
Includes Presser Foot	10185		
Shank	10155		
Block	10156		
Bolt	10182		
Nut	NJ 10		
2" Stitch		31124	10079 (3 Ctr. Teeth)
Filler Cord (R/C)	10285	31116	10078
2" Stitch	10285	31124	10079
Rotary Knife (110V)	31130		
(24V)	31100		
Blade, Movable Knife	31112		
Blade, Fixed Knife	31113		
Two Thread Looper	10060		
Needles	C100-S	Square Point for Paper	
	C100-RP	Round Point used for woven poly, burlap.	
	C80-S	0.08" Diameter Square Point	

9.2 MODEL 201

<u>PRESSER FOOT</u>		<u>THROAT PLATE</u>	<u>FEED DOG</u>
Std. Wide Tape (2" – 2 1/2")	10484	31125	10486
Std. Wide Tape Assy.	10481	31125	10486
Includes Presser Foot	10484		
Shank	10155		
Block	10156		
Bolt	10182		
Nut	NJ 10		
Narrow Tape (1 1/4" – 1 1/2")	10494	31126	10496
Narrow Tape Assy.	10490	31126	10496
Includes Presser Foot	10494		
Shank	10498		
Block	10497		
Bolt	10499		
Nut	NJ 10		
Medium Tape (1 7/8") (Pull Tape Same Parts)	10562	31125	10565
Wide Pull Tape (Base Only)	10558	31125	10486
Narrow Pull Tape (Base Only)	10553	31125	10496
Tape or Chain (Brussels Only)	10479	31127	10491
Two Thread Looper	10060		
Single Thread Looper	10208		
Needles	C100-S	Square Point for paper (0.100")	
	C100-RP	Round Point for woven poly, burlap	
	C80-S	0.08" Diameter Square Point	
Throat Fence	10449		
Moving Knife	10443		
Bed Knife	10446		

10. SAFELY DISPOSING OF A SEWING HEAD

If a Model 200 or 201 sewing head becomes damaged beyond repair or simply worn to a nonfunctional state after years of service, it should be put out of service only after it is safe to dispose of it. First, drain all the oil out of the machine as described in section 2.4 of this manual. Dispose of the oil according to your appropriate local environmental regulations. After the oil has been drained and disposed of, bring the sewing head to a recycling center or metal scrap facility.