

**INSTRUCTION MANUAL FOR LGO
GROSS BAGGING SCALE
MODEL GB-17, GB-25, GB-32,
GBAO-21, GBAO-25, GBAO-31 & GBAO-37**

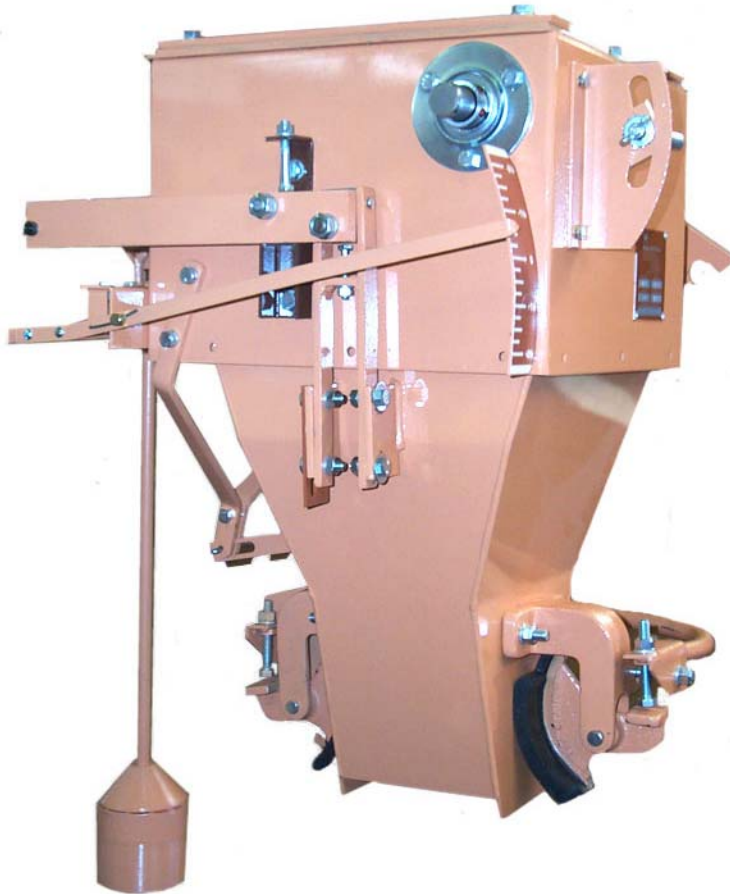

*****LGO 'K VGTP CVKQP CN
6873 MARTINDALE RD. SHAWNEE, KANSAS 66218
(913)441-478: FAX: (913) 441-1711

GENERAL

Your JEM gross bagging scale is designed to weigh within plus or minus 4 ounce accuracy (100 gram) on all free flowing materials such as corn, soybeans, salt, pellets, prilled fertilizers, sugar, etc. The GB-17, GB-25 and GB-32 scales are non dust tight and designed for handling 20 lb. (10 kg.) through 110 lb. (50 kg.) weighments at a rate of 5 to 6 bags per minute. The GBAO series scales are designed for dusty free flowing products at the same speed and accuracy.

GB-17, GB-25 & GB-32 Scales

Actual Weight	175 lbs. (80 kgs.)
Overall Height	26" (60 cm)
Inlet	9" x 7" (22.5 cm x 17.5 cm)
Spout Circumference	GB-25 equals 25" (63.5 cm) GB-32 equals 32" (81 cm)

*No electricity required

*No air required

GBAO Series Scales

Actual Weight	250 lbs. (114 kgs.)
Overall Height	27.50" (69.9 cm)
Inlet	9" x 7" (22.9 cm x 17.8 cm)
Spout Circumference	GBAO-21 equals 21" (53.5 cm) GBAO-25 equals 25" (63.5 cm) GBAO-31 equals 31" (78.7 cm) GBAO-37 equals 37" (94.0 cm)

*No electricity required

*100 PSI Air at 2 to 3 cubic feet per minute

PLANNING YOUR HOPPER BEFORE INSTALLATION OF SCALE

Check the chart for the actual weight of your bagging scale. The flange on your hopper will need to support the scale plus the weight of your heaviest bag plus any product inside the scale. Most installations utilize 1/4" flange material or heavier for supporting the scale. The drawings on pages 16 and 17 should provide a good reference for constructing the hopper.

Most free flowing products will flow down a 60° slope. When designing hoppers, it is best to have no less than 60° slope. Some products flow better with one straight wall and three 60° slope walls. Other products will flow with four 60° slope walls. When constructing the hopper, remember that vibration can effect accuracy and the hopper should be isolated from as much plant vibration as possible. The normal height for operating the scale is for the bottom of the scale to be 48" (1.2 meters) from floor level. The top of the GB-32 or GB-25 scale would be 74" (1.87 meters) from floor level and the top of the GBAO series scales would be 75.5" (1.92 m) from floor level. The 48" (1.2 m) from the bottom of the scale is normally set at 3 ft. (90 cm) for the bag and 1 ft. (30 cm) for the bag closing conveyor. If the bag is taller than 3 ft. (90 cm) then the overall height of the scale will have to be adjusted accordingly.

TO INSTALL YOUR GB BAGGER

Install the bagging scale on the flanges. Once on the flanges, tighten down the three bolts (6 total) on each side so the scale is rigidly connected to the flange. Make sure that the scale is hanging plumb and level.

Loosen the two bolts on the spout that hold the shipping clip in place on both sides of the scale. Two bolts on the right hand side of the spout should be loosened, the shipping clip should be pushed to its lowest position and the bolts re-tightened.

Two bolts on the left side of the spout should be loosened, lower the shipping clip to its lowest position and re-tighten. At this point, the spout and the scale should be free.

Hang the weight rod on the main beam clevis hook at the back of the scale making sure that the open part of the hook faces away from the scale.

Add dashpot oil to your dashpot located on the right rear of the scale. Oil is entered into the dashpot through the oiler on the side of the dashpot. 2 oz of dashpot oil has been provided with the scale and the dashpot will take 90% of this oil provided. Additional dashpot oil can be ordered through the manufacturer or utilize a non temperature sensitive 200 weight silicone oil. If incorrect dashpot oil is used, it can effect the operation of the scale.

On GBAO models, connect the flex connection to the spout using the brackets and bolts provided.

On GBAO models, connect incoming airline to filter regulator lubricator system on right front of scale. Regulate air pressure to hold the bag firmly in place when filling. Normally 60 to 90 PSI air pressure is sufficient.

Add a medium weight hydraulic oil to the regulating bowl. The regulator should produce 1 drop of oil every 2 or 3 bags. The adjustment for this is on the top of the regulator.

ADJUSTMENTS

Your JEM gross bagging scale has been calibrated at the factory prior to shipment. Only the following adjustments should be made by you. If you experience any problems not covered by these adjustments, please contact us by telephone (913-441-4788) before making any additional adjustments.

Bag Balance Weight (right front of scale)

When your scale is mounted to the hopper and has the weight bar attached (without weights), the weight indicator should point to zero. If not, adjust the indicator to zero by rotating the bag balance weight. The bag balance weight is also used to compensate for the weight of the bag. Attach an empty bag. Now rotate the bag balance weight so that the weight indicator again points to zero.

Trigger Trip Screw (right rear of scale)

This is your adjustment for light or heavy material weight in the bag. It accounts for the materials in suspension between the shut-off gate and the bag (similar to the water in the hose between the valve and the end of the hose).

If your bags are consistently weighing light, the trigger trip is too sensitive and trips early. Adjust the screw upward. This will allow additional weight in the next bag. Do not attempt to adjust the trigger trip screw during the filling of a bag.

Regulating Slide (left front of scale)

Some materials are heavier and some flow more freely than others. When weighing a heavy, fast flowing material, the opening should be smaller so that materials flow slower. Excessive flow causes inaccurate weighing. When shipped, the regulating slide has a small opening. To increase it simply loosen the wing nut, pull handle down and re-tighten wing nut.

Note: A change in the adjustment of the regulating slide will require

re-adjustment of the trigger trip screw.

Dashpot (right rear of scale)

The dashpot is the buffer between the scale and the pointer. Without a dampening device the pointer would never settle down. The dampening effect is accomplished by a metal plate about the size of a quarter riding up and down in an oil bath. The oil is a non temperature sensitive 200 weight silicone oil-dashpot oil. The dampening effect is changed by turning the dashpot lid. The oil should completely fill the oiler to the top, approximately 2 oz. total. Change oil when dirty or approximately every 6 months.

Main Beams, Pivots & Bearings (both sides of scale)

The bearings and pivots on both sides of the scale have bolts approximately 1/8" (3 mm) from them to prevent them from jumping during operation. Please be sure that these bolts do not touch the bearings or pivots and that the gap spacing is correct.

Compensation Spring

The compensation spring is used to help place the beam in motion. The beam should contact the spring before it reaches the beam stop bracket on the downward or empty position. The beam should be free or clear of the spring before the final cutoff. The compensation spring can easily be bent up or down to adjust.

OPERATION

Place empty bag on spout of scale, spin bag balance weight (right front side) until pointer on left side of scale returns to 0. Pull down on empty bag several times watching pointer each time to ensure that it returns to 0. If not, check for possible binds in scale.

Possible Binds

- *Dashpot is not lined up squarely and rubbing.
- *Check sway control link to make sure it is not pushing or pulling on spout
- *Check to see that the weight rod has been installed correctly with the open part of the hook facing away from scale.
- *On GBAO models, make sure airlines are not tight.
- * On GBAO models, make sure flex connection is not tight.
- *Comp spring should contact beam.

The scale is a 5 to 1 calibrated beam scale. The weights have been marked according to the amount of product in the bag they will counter balance. A 25 lb. weight actually weighs 5 lbs., but will counter balance 25 lbs. of weight in the bag. Place the desired amount of weights on the weight rod to counter balance target weight of bag. For example, a 50 lb. bag would require two 25 lb. weights or a 40 kg. bag would require 4 (10 kg.) weights.

Pull feed gate handle (upper right of scale) locking trigger assembly on roller bearing. This should be a gentle soft motion. The internal gate of the scale will be opened thus allowing product to fall through the scale into the bag. When the beam comes toward balance, it will trip trigger trip screw (right rear of scale), thus allowing gate to close.

At this point, balance indicator (left front of scale) will display actual weight in the bag as an over or under from target weight. If weight is over target weight, trigger trip screw (right rear of scale) will need to be lowered. If weight is short of target weight, then trigger trip screw (right rear of scale) will need to be raised.

Flow control adjust (left front of scale) is used to control speed at which product falls into the bag. Speed should not be faster than 10 lbs. (5 kg.) per second in order to maintain a repeatable weight. If speed is too fast, then raise the regulating slide handle. Subsequently if speed is too slow, then lower the regulating slide handle.

On GBAO series scales, the foot pedal will open and close bag clamps. Normal operation is for the bag clamps to be in the closed position. When the foot pedal is activated, the bag clamps will open thus releasing a filled bag. At this point, an empty bag would be placed on the spout and the foot pedal released thus holding next bag in position. In normal operation, the operator does not have to stand with his foot on the foot pedal during filling.

DUST PICKUP ON GBAO SERIES SCALES

A dust port has been provided (left rear of scale) to pickup displaced air from the bag during filling operation. It is extremely important to remember that too much vacuum or negative air can cause weight inaccuracies on the scale, therefore, take a filled bag with product on the scale, check the position of the balance indicator (left front of scale). Now apply negative air pressure to the port (left rear of scale), watch balance indicator. If balance indicator moves when negative air is applied, then too much air pressure has been utilized and back off the amount of air pressure until the balance indicator returns to it starting position. It is extremely important to remember that this must be tested while a bag is on the spout.

TIPS TO REMEMBER

The GB series scales are designed for handling free flowing products if a feeder has not been provided. Accuracy is normal at plus or minus 4 oz (100 grams).

Normal speed is 5 to 6 bags per minute maximum. The fill weight is never more than 10 lbs. (5 kg.) per second. The feed gate handle is normally gently pulled and positioned locking the trigger on the roller bearing. Be sure that no one adjusts the bolt behind the roller bearing to allow for the trigger to be more easily set into the roller bearing. This adjustment has been made at the factory and does not need to be re-adjusted.

BELT FEEDER (SINGLE MOTOR-STREAM DEPTH REGULATOR)

The belt feeder is used for semi free flowing products and is motor driven. The feeder comes complete with a stream depth regulator, manually adjusted. For setting the belt feeder for optimum accuracy/production, the slow feed should be set to allow no more than 10 lbs. per second of material flow. This can be easily adjusted by manually adjusting the stream depth regulator on top of the belt feeder. In the event some product cannot be slowed to this level, then contact the factory. It may be necessary to change the sprocket and slow down the belt feeder.

The unit should fill at approximately 10 lbs. per second (this is a guide and not a set value), size and density will effect filling rates. Using the handle attached to the flow gate, screw in to increase and out to decrease.

Before operating scale, recheck belt tracking (see instructions)

Maintenance for belt feeder:

- Lubricate 4 main bearings weekly

- Lubricate 2 gate bearings periodically

- Check gear box for proper lubrication level

- Periodically check gate and belt seal for wear and leakage

BELT TRACKING INSTRUCTIONS

The belt rides between a head and tail pulley with the head pulley in a fixed non-adjustable position and the tail pulley is adjustable through plates and bolts mounted outside the feeder assembly. See figures 1 and 3.

On one side adjust distance from the center of pulleys to 24" (60cm).

On opposite side adjust the pulleys to the same distance but leave the tail pulley loose.

Adjust for belt tracking utilizing this bolt assembly as shown in figures 1 and 3.

The support plate that supports the belt between the pulleys should be in its lowest position. See figure 2. Check to make sure the 4 support bolts are secure before actual running.

The 24" (60cm) between center of pulleys is critical for belt tension. This figure may vary slightly on belts as they do stretch. If the variance is too great then the belt is too tight and can cause damage to the pulleys.

The belts should be tight enough to track between the pulleys but not too tight to put excessive wear on the shafts of the pulleys.

After the belt has been tracked and witnessed for at least 20 minutes of operation then be sure all of the support belt bolts are securely tightened. The adjustment bolt is not strong enough to support the tail pulley assembly during the actual operation.

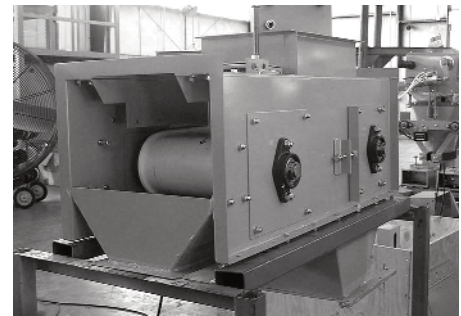

Fig 1



Fig 2

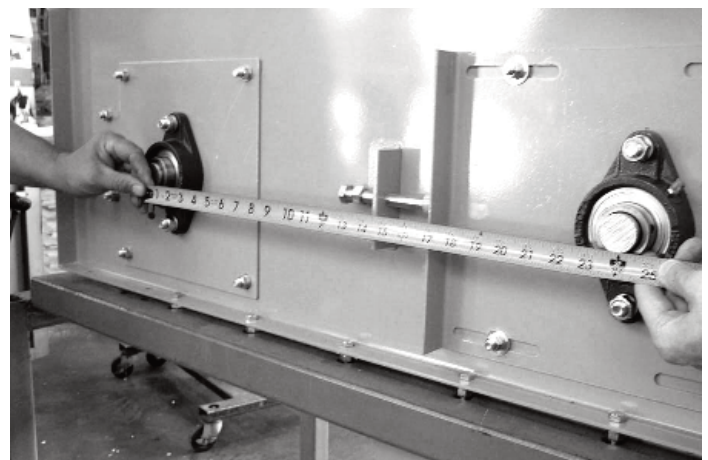

Fig 3

CHANGING SPOUTS

Should you need to change one spout for another, the process is fairly simple. Remove the first spout by pulling the two clevis pins in the V blocks on both right and left side of the scale. These clevis pins are inserted through the H brackets that connect the spout to the main beam. Once these pins are pulled, the spout will be allowed to fall from the scale. The spout will be held by the sway control bracket on the back of the scale. After the spout is held by the sway control bracket, then get a better grip on the spout and remove the cotter pin from the sway control bracket, thus releasing the spout from the scale.

The new spout is ready for installation. Check the distance between the H brackets on the old spout and the H brackets on the new spout. This distance must be repeated exactly. If the distance between H brackets is not exactly the same then side movement will occur and cause inaccuracies. Be extremely careful to check this spacing prior to installing the new spout.

Once the new spout is installed, remember the spout has been calibrated against the weight in the weight cup on the bottom of the weight rod back of scale. The scale is a 5 to 1 beam meaning the spout weighs 5 times as much as the weight rod. The weight rod was counter balanced for the spout that was removed. The new spout will not weigh the same as the old spout. We will need to adjust the weight of the weight rod. The beam when in the level position should have the pointer at zero. Check this position and correct by using the turnbuckle (left rear of scale).

Add or subtract weight from the weight cup until the beam now is level and pointer is at zero with new spout installed. Once the correct weight is reached,

then re-tape the weight cup. Any weights such as bb's, washers, nuts and bolts can be used inside the weight cup for this purpose.

CALIBRATION

The scale has been pre-calibrated at the factory. The calibration steps are used only in the event of new bearings and pivots being purchased.

GB CALIBRATION STEPS

1. Torque torsion rod both ends and make sure it does not rub.
2. Level beam with housing which should be level.
3. With beam level, set turnbuckle until indicator reads zero.
4. Check compensation spring and make sure it is set to be free of beam at (-)1.
5. Set main beam stop bolt at (+) 2, lock nut down.
6. Check dashpot and make sure it is plumb and center.
(make sure it does not rub)
7. Check that shipping clips are down and not touching housing.
8. Calibration
 - a. Set bag balance weight flush with end of rod.
 - b. Add shot to weight cup until indicator reads zero
 - c. Hang empty bag or device to hang weights and use bag balance weight to make indicator read zero.
 - d. Add weights to weight rod and weight to bag. This is a 5 to 1 beam and weights supplied with bagger are marked 5 times their weight for ease in calculating. Example: (10 lb. is marked 50 lb.)
 - e. With equal ratio weight, preferably 100 lbs. or 50 kg. or as close to this as possible, indicator should read zero. If not zero perform steps f to i.
 - f. Move the left pivot to zero and move the right pivot to the other side of zero than was reading. (If it reads (+) 1, move left pivot to zero, then move the right pivot to (-) 1).
 - g. Remove all weight and re-hang bag.
 - h. Check zero, add or remove shot.
 - i. Re-hang weight and check weight read. If not zero, repeat steps f to i.

If after several tries you cannot bring bagger into calibration, please call for assistance, 913-441-4788.

UNDERSTANDING YOUR SCALE

The GB series scales are extremely simple to operate and the adjustments are also extremely simple to do and understand. It is best to adjust the scale for accuracy, then second adjust the scale for speed. Never adjust for speed and accuracy at the same time. The trigger trip screw (right rear of scale) is your adjustment for accuracy. The flow control adjust (left front of scale) is your main adjustment for speed. These two adjustments are never to be adjusted at the same time.

Spare parts are available from either your distributor who supplied you with the equipment or by contacting Jem International, 6873 Martindale, Shawnee, Kansas 66218, Phone: 913-441-4788 or Fax: 913-441-1711.

BELT TRACKING INSTRUCTIONS

The belt rides between a head and tail pulley with the head pulley in a fixed non-adjustable position and the tail pulley is adjustable through plates and bolts mounted outside the feeder assembly. See figures 1 and 3.

On one side adjust distance from the center of pulleys to 24" (60cm).

On opposite side adjust the pulleys to the same distance but leave the tail pulley loose.

Adjust for belt tracking utilizing this bolt assembly as shown in figures 1 and 3.

The support plate that supports the belt between the pulleys should be in its lowest position. See figure 2. Check to make sure the 4 support bolts are secure before actual running.

The 24" (60cm) between center of pulleys is critical for belt tension. This figure may vary slightly on belts as they do stretch. If the variance is too great then the belt is too tight and can cause damage to the pulleys.

The belts should be tight enough to track between the pulleys but not too tight to put excessive wear on the shafts of the pulleys.

After the belt has been tracked and witnessed for at least 20 minutes of operation then be sure all of the support belt bolts are securely tightened. The adjustment bolt is not strong enough to support the tail pulley assembly during the actual operation.

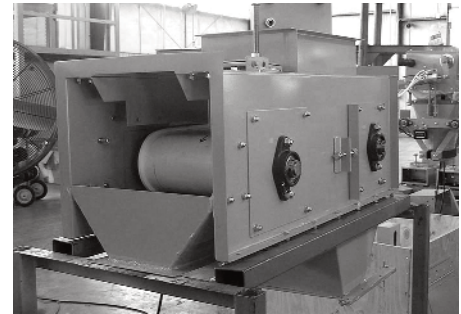

Fig 1



Fig 2

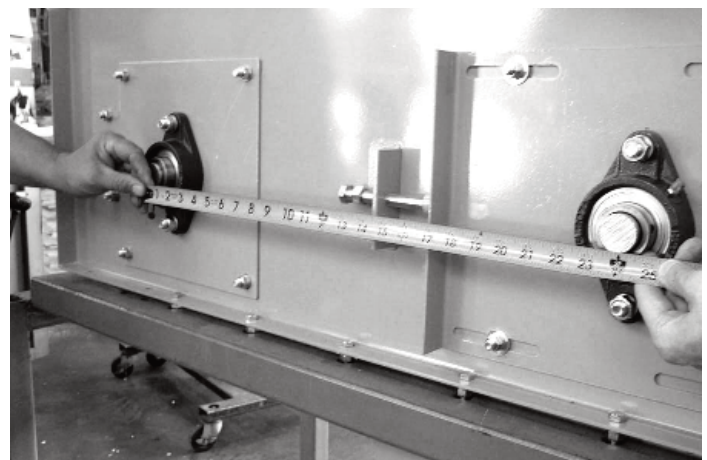
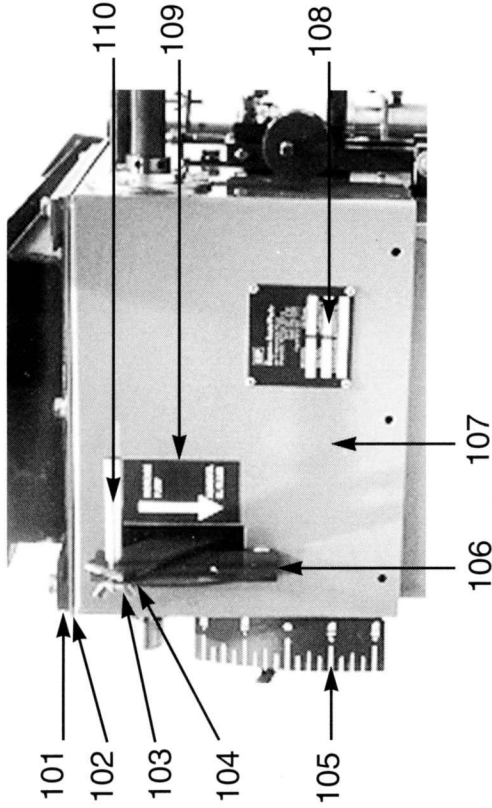

Fig 3

FIGURE 1



INDEX #	PART#	DESCRIPTION	#USED
101	0379823601	Slide Bar	2
102	0379833601	Slide Bar Spacer	2
103	4425950000	Wing Nut	1
104	4425120000	Washer, Special	1
105	7675400001	Decal LB	1
	7675400002	Decal KG	1
106	0418183501	Plate, Regulating Slide	1
107	5424250001	Housing	1
108	9300030000	Nameplate	1
109	7675400003	Decal Flow	1
110	0418176601	Handle, Regulating Slide	1

FIGURE 2

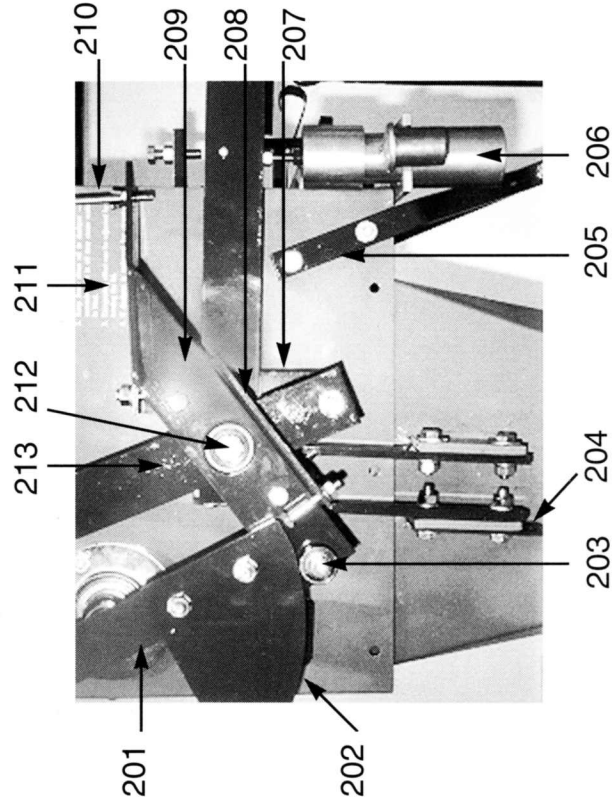

INDEX#	PART#	DESCRIPTION	#USED
201	5424260001	Handle Gate	1
202	0423757001	Knife Edge	*1
203	7055550000	Bearing Knife Edge	*1
204	0398253501	Shipping Clip	2
205	5460190001	Bracket Sway Control	2
206	6000470001	Dashpot Assembly	*1
207	5460160001	Middle Bearing Bracket	2
208	5460230002	Bracket Tr. Arm Bearing	*1
209	5460230001	Trigger Arm	1
210	4743440000	Screw Trigger Trip	*1
211	9300040000	Dashpot Instructions	1
212	7055000000	Bearing Trigger Arm	*1
213	0423793601	Bracket, Trigger Arm Mt.1	1
not shown			
	0034053614	Spacer, Upper	1
	0034053626	Spacer, Lower	1

* Indicates items recommended for spares

FIGURE 3

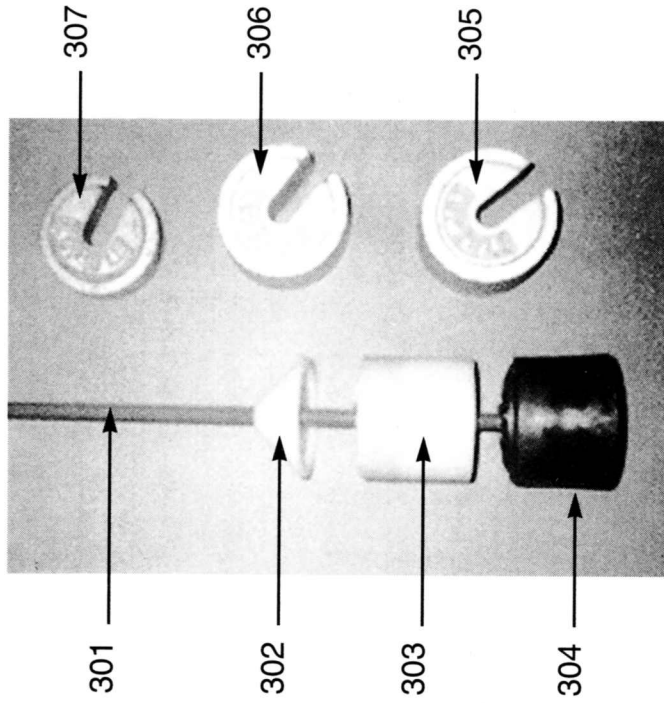

INDEX#	PART#	DESCRIPTION	#USED
301	5447930001	Weight Rod	1
302	9250400000	Weight Box Cover	1
303	9267080000	Weight Box	1
not shown			
304	0372813501	Weight Box Lid	1
		Weight (option for AO scale only)	1
305	6011400005	25 LB. weight	4
306	6011400002	10 LB. weight	1
307	6011400001	5 LB. weight	1
	6011400026	full set of LB. weights	1
	6011500005	10 KG. weight	4
	6011500002	5 KG. weight	1
	6011500001	2.5 KG. weight	1
	6011500018	full set of KG weights	1

FIGURE 4

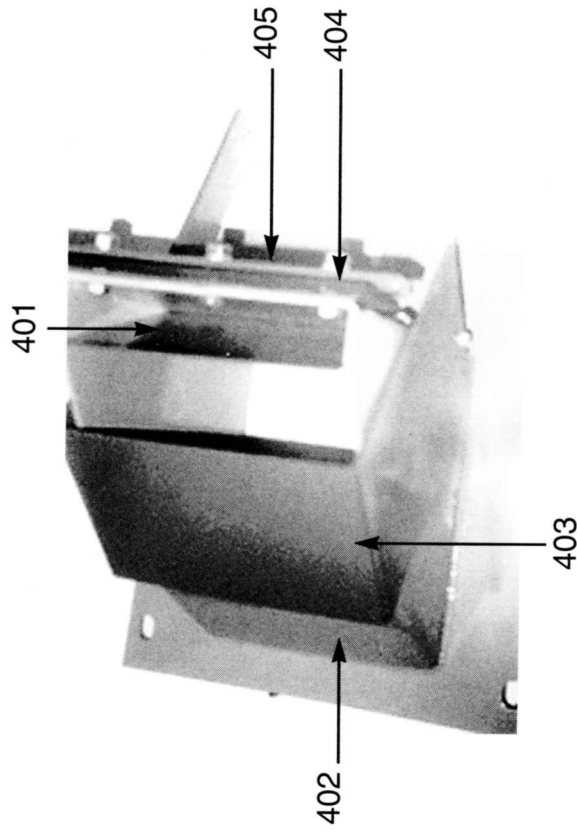

INDEX#	PART#	DESCRIPTION	#USED
401	0467603501	Restrictor Plate	1
402	5418150001	Chute Top	1
403	5418220001	Regulating Slide	1
404	0024257910	Seal Chute	*1
405	0379943601	Gate Stop Bar	1
not shown	0024257911	Plate Seal	1
not shown	5423910001	Chute Gate	1

*Indicates items recommended for spares

FIGURE 5

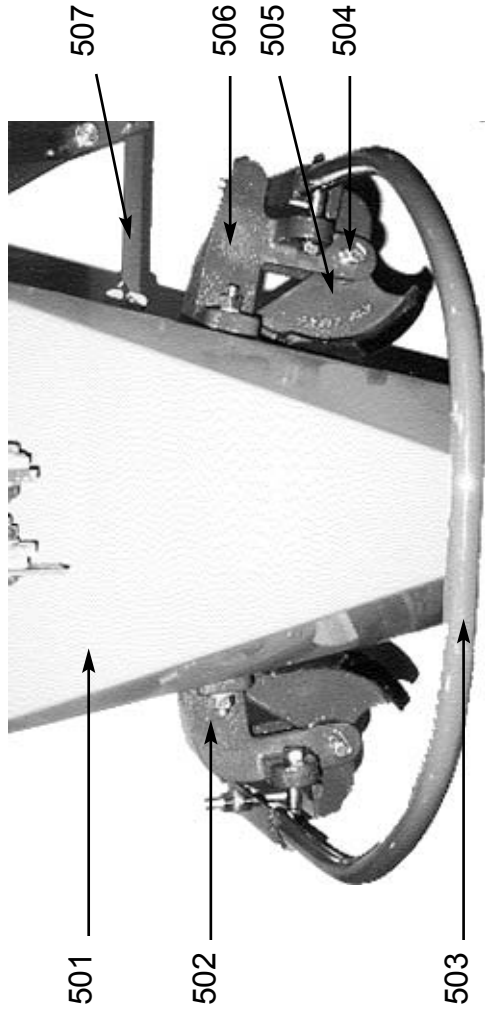

INDEX#	PART#	DESCRIPTION	#USED
501	5479500001	Spout - 32"	1
	5419900001	Spout - 25"	1
	5419910001	Spout - 17"	1
502	0479350101	Bracket Bagholder Front	1
503	5460220007	Handle Release - GB32	1
	5460220003	Handle Release - GB25	1
504	4496600000	Pin Fulcrum	2
505	5363180001	Bag Clamp (includes pin)	2
506	0479360101	Bracket Bagholder Rear	1
507	0423943601	Sway Link	1

* Indicates items recommended for spares

FIGURE 6

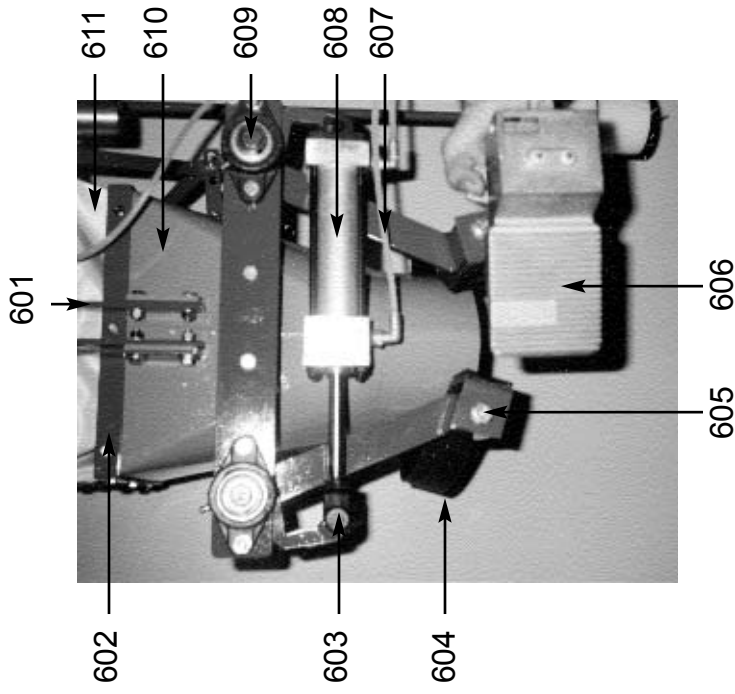

INDEX#	PART#	DESCRIPTION	#USED
601	5454480002	H Bracket	2
602	0447973601	Bar Dust Skirt	8
603	8333260002	Clevis	1
604	3799990000	Bag Clamps	*2
605	5448200004	L Bracket	4
606	8953050002	Valve Foot	1
607	8282504444	Airline	*30ft.
608	8333260000	Cylinder Spout	1
609	7623140002	Bearing	4
610		Spout AO 31	1
611	7791780000	Dust Skirt	*1
not shown	3770330040	FR	1
not shown	8282509999	Vent	*1

FIGURE 7

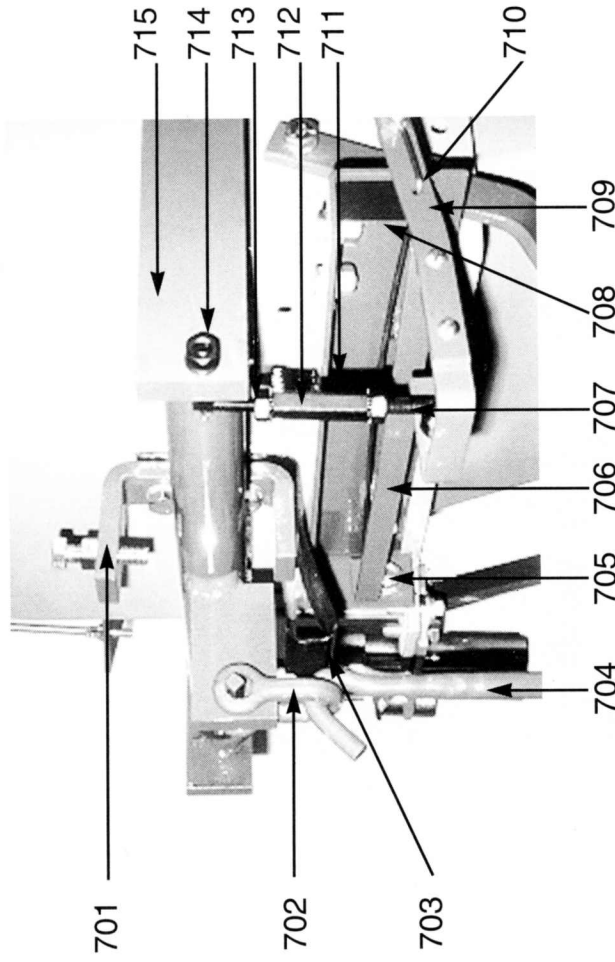

INDEX #	PART #	DESCRIPTION	#USED
701	5460180001	Bracket Beam Stop	1
702	0015480000	Clevis	1
703	7811270000	Compensation Spring	*1
704	5447930001	Weight Rod	1
705	0379725501	Torsion Adjust Bolt	1
706	0444455501	Bar Bearing	1
707	04444395501	Pushrod RH	1
709	0423965501	Pointer	1
710	0379715501	Torsion Rod	*1
711	0444425501	Turnbuckle Ass'y.	*1
712	0444405501	Turnbuckle	1
713	0444385501	Pushrod LH	1
714	0444415501	Pushrod Pin	2
715	6000420000	Main Beam	1
not shown	0423995501	Angle Support	1

* Indicates items recommended for spares

FIGURE 8

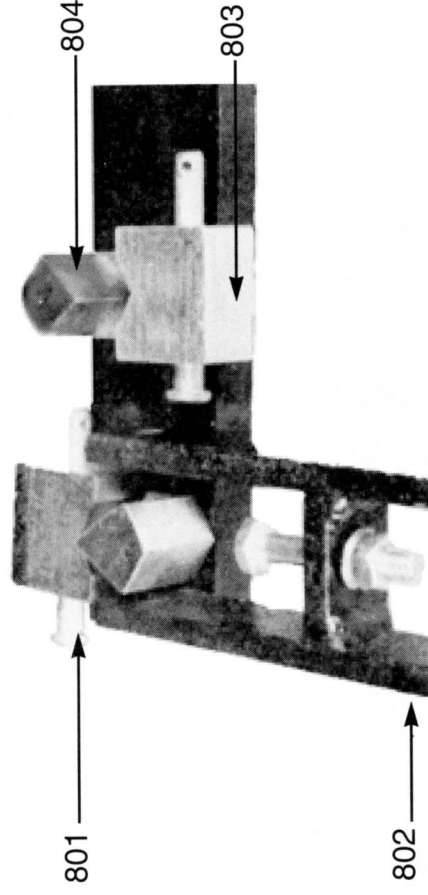

INDEX#	PART#	DESCRIPTION	#USED
801	0381156601	Pin Clevis	4
802	5454480001	Suspension Shackle	2
803	0098353801	Bearing	4
804	0270063801	Pivot	4

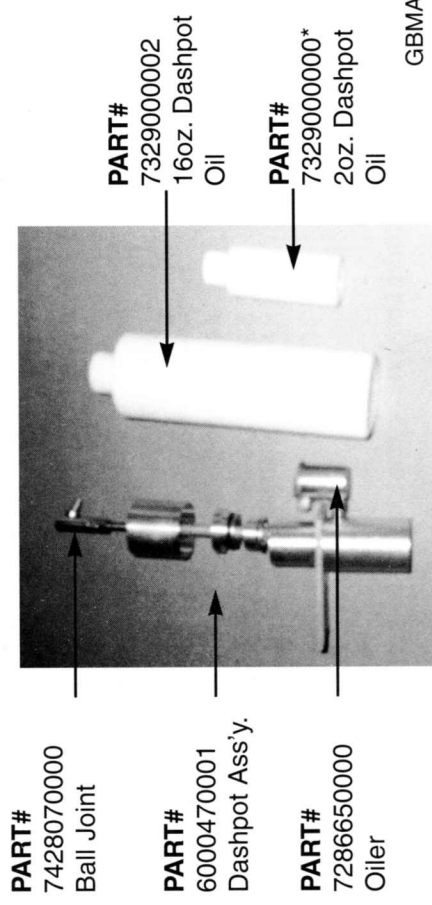

GBMAN

**BELT FEEDER (SINGLE MOTOR-STREAM DEPTH REGULATOR)
(GROSS WEIGH-D)**

The belt feeder is used for semi free flowing products and is motor driven. The feeder comes complete with a stream depth regulator manually adjusted. For setting the belt feeder for optimum accuracy/production, the slow fed should be set to allow no more than 10 lbs per second of material flow. This can be easily adjusted by manually setting the stream depth regulator on top of the belt feeder. In the event some product cannot be slowed to this level, then contact the factory. It may be necessary to change the sprocket and slow down the belt feeder.

The unit should fill at approximately 10 lbs. per second (this is a guide and not a set value), size and density will affect filling rates. Using the handle attached to the flow gate, screw in to increase and out to decrease.

Before operating scale, recheck belt tracking.

Maintenance Belt feeder

1. Lubricate 4 main bearings weekly.
2. Lubricate 2 gate bearings periodically.
3. Check gear box for proper lubrication level.
4. Periodically check gate and belt seal for wear or leakage.

GB/GBAO BELT FEEDER

