

REV. A	JEM INTERNATIONAL, INC.			
REV. B	6873 MARTINDALE RD. SHAWNEE, KANSAS 66218 (913) 441-4788			
REV. C	NAME GWD WILDCAT BELT FED GROSS WEIGH SCALE, MODEL BC-8 CONVEYOR, SEW PED, 10' INCLINE, ROLLER TABLE, BISHAMON EZ-30			
REV. D				
REV. E	FOR			
REV. F	TOLERANCE	MATERIAL	SCALE D.N.S.	PART NUMBER
REV. G	DRAWING NUMBER GWD-61	DRAWN BY J GOUDY	DATE 11-01-14	PART NUMBER

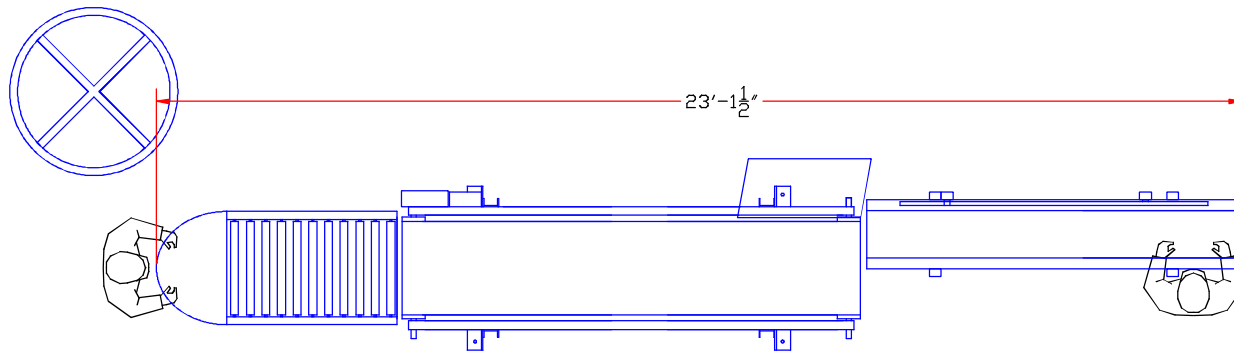

NOTE: CUSTOMER'S FLANGE TO SUPPORT BELT FEEDER SHOULD BE 18x18x1/2" FLANGE x 1/4" THICK MATERIAL MINIMUM. EXTRA SUPPORTS CAN BE ADDED FROM TOP EDGE OF BELT FEEDER TO CONNECT TO HOPPER

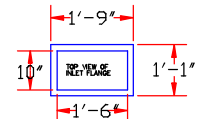

FBF - Flex Belt Feeder
Optional - VSD 2-speed filling

GWD - Wildcat
Gross Weigh Digital Scale
with Dust Tight spout

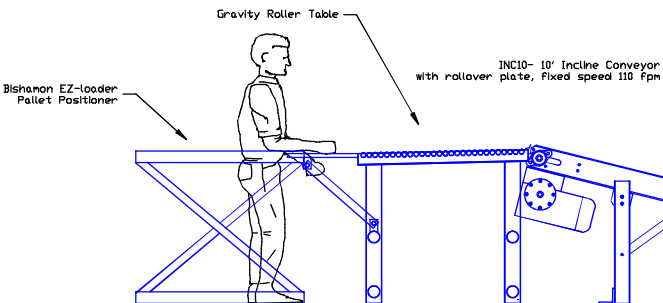
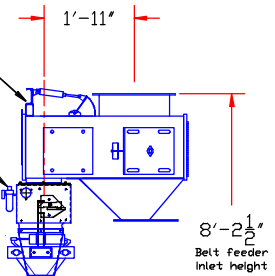

Industrial Sewing Pedestal-
US80800C Sew head and thread pusher

BC-8 Bag Closing Conveyor
Adjustable VSD motor controls

