

NOTE: CUSTOMER'S FLANGE TO SUPPORT BELT FEEDER SHOULD BE 18x10x1 1/2" FLANGE x 1/4" THICK MATERIAL MINIMUM.

EXTRA SUPPORTS CAN BE ADDED FROM TOP EDGE OF BELT FEEDER TO CONNECT TO HOPPER

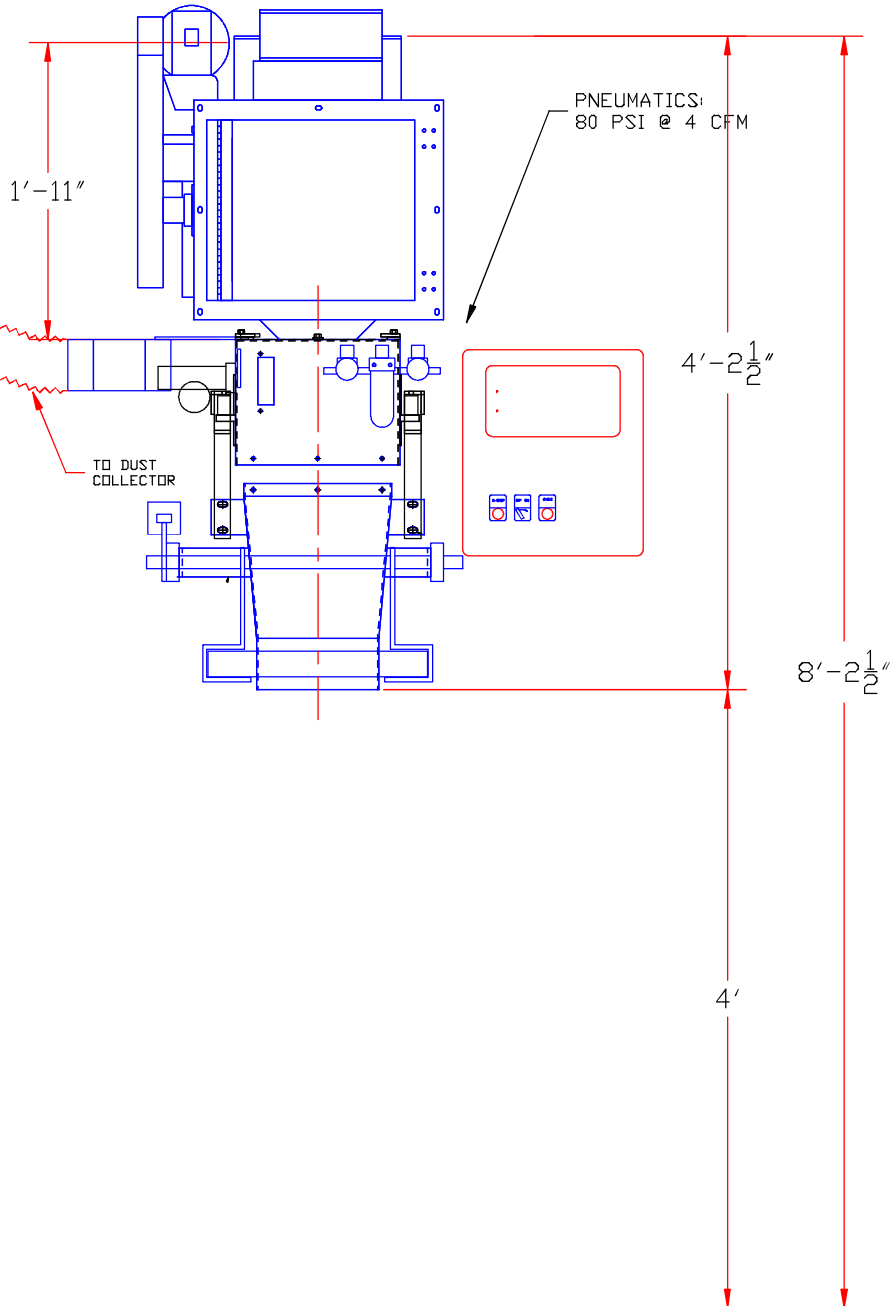

FBF BELT FEEDER

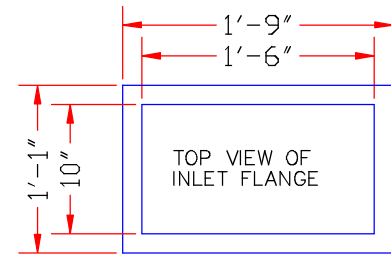
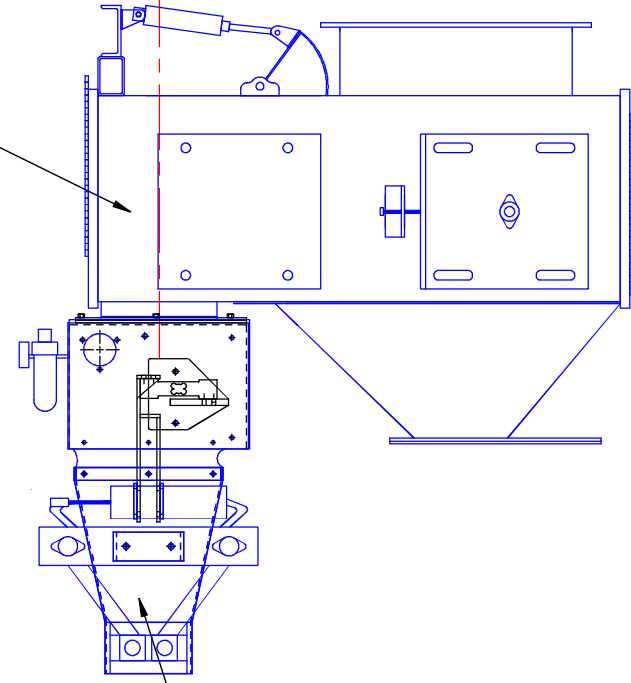

GW-D WILDCAT GROSS WEIGH SCALE (SHOWN WITH DUST TIGHT SPOUT)

REV. A	<i>JEM INTERNATIONAL, INC.</i>		
REV. B	6873 MARTINDALE SHAWNEE, KANSAS 66218 (913) 441-4788		
REV. C	NAME		
	GWD-FBF-D GROSS WEIGH BELT FED SCALE		
REV. D	FOR		
REV. E			
REV. F	TOLERANCE	MATERIAL	SCALE
			D.N.S.
REV. G	DRAWING NUMBER	DRAWN BY	DATE
	GWD-56	COUGHLIN	09-22-14